

A MATHEMATICAL FORMULATION FOR ESTABLISHING
THE RELATIONSHIP OF ACCURACY AND CONFIGURATION OF DATA
ACQUISITION IN CLOSE RANGE PHOTOGRAMMETRY

تكوين العلاقات الرياضية لدراسة العلاقة بين الدقة والشكل للوضع الأمثل
في اكتساب المعلومات في مجال المساحة التصويرية الأرضية ذات المدى
القصر

A.B. EL-ORABY

Civil Engineering, El-Mansoura University
El-Mansoura, Egypt

الخلاصة - من المعلوم أن اكتساب المعلومات في مجال المساحة التصويرية الأرضية ذات المدى
القصر يتوقف أساساً على :

- ١ - تحديد خط قاعدة النموذج الجسم .
- ٢ - البعد عن الهدف المرصود .
- ٣ - زاوية التقاط .

تلك العناصر التي يتحدد بها الوضع والشكل النهائي الأمثل للنموذج الجسم وتوجد العديد
من الأبحاث والدراسات المنشورة التي قامت بدراسة دقة الموديل الموديل الجسم كما في
الأبحاث المنشورة إلا أن هذا البحث يعتبر إضافة جديدة في هذا المجال والذي يتركز في إيجاد
العلاقة بين دقة تحديد إحداثيات أي هدف مرصود وعلاقته بالوضع والشكل الأمثل للنموذج
المرصود بالدرجة الأولى بعناصر الضبط الخارجي وقد تعرض هذا البحث باستنباط العلاقات
الرياضية في هذا الخصوص وتم تطبيقها في تحديد الشكل والوضع الأمثل الذي يعطي أحسن النتائج
من ناحية الدقة .

ABSTRACT - Configuration of data acquisition in close range photogrammetry is defined by (1) the base, which is the distance between the exposure stations of a stereopair, (2) the object distance, which is the perpendicular distance from the center (midfield) of object space to the base, and (3) the convergence of the two camera axes. The accuracy of object space coordinates of points is a function of configuration. A mathematical formulation establishing the relationship of accuracy and configuration is derived and then applied to obtain the optimum configuration, that gives the best accuracy in close range photogrammetry applications. The formulation developed is general and can be applied to calculate the expected accuracy of any given configuration, or to design a configuration that will yield a required accuracy.

1- INTRODUCTION

Basically, the term configuration of data acquisition in close range photogrammetry refers to the exterior orientation of the stereopair of photographs taken of a certain object space. It consists, therefore, of the object space coordinates of the two perspective centers (exposure stations), and the rotational attitudes (ω , φ , κ) of the two photos. The distance between the exposure stations is the base, and the perpendicular distance from the center of object space (midfield) to the base is taken as the object distance. The ω -rotations, or tilts, of the two photos are rotations about axes parallel to the base. The κ -rotations, or swings are rotations about the camera axes. The φ -rotations, rotations about axes perpendicular to both the base and the camera axes, define what is referred to as convergence. Some authors (Faig, W. /2/, Gruner, H. /3/) define convergence as the actual angle between the two camera axes while others treat each φ -rotation as the convergence of each photo. In many close range applications, for a more efficient photographic coverage of object space, the tilts are generally made equal or their difference made very small, while the swings are generally made very small or close to zero. Therefore configuration of data acquisition is defined by

the parameters; the base, the object distance and the convergence. The accuracy of object space coordinates of points is a function of configuration of data acquisition. The configuration that gives the best accuracy of object space coordinates is the optimum configuration.

2-THE NORMAL CASE OF PHOTOGRAMMETRY

When the convergence is zero, we have the normal case of photogrammetry. Figure 1 shows the configuration for the normal case. O_1 and O_2 are the exposure stations, P is a point in object space with images P_1 and P_2 . C_1 and C_2 are the principal distance for the left and the right photos, respectively. From Figure 1, if we put $c_1 = c_2 = c$, we have the basic relationships:

$$\begin{aligned} \frac{Z}{c} &= \frac{B}{x_1 - x_2} & \frac{x - B}{Z} &= \frac{x_1}{c} \\ \frac{X}{c} &= \frac{x_1}{c} & \frac{Y}{Z} &= \frac{y_1}{c} = \frac{y_2}{c} \end{aligned} \quad \dots (1)$$

where

- x_1, y_1 = photo coordinates of a point in the left photograph
- x_2, y_2 = photo coordinates of the point in the right photograph
- X, Y, Z = object space coordinates of the point, Z also is the object distance, in this case.
- B = base

If $m_{x1}, m_{y1}, m_{x2}, m_{y2}$ are the standard errors of photo coordinates, and assuming $m_{x1} = m_{x2} = m_x$ and $m_{y1} = m_{y2} = m_y$, we obtain from (1), by the law of propagation of errors, the object coordinate errors, as follows:

$$\begin{aligned} m_X^2 &= \frac{Z^2}{B^2 c^2} [X^2 + (X - B)^2] m_x^2 \\ m_Y^2 &= \frac{Z^2}{c^2} \left[\frac{1}{2} + 2 \left(\frac{Y}{B} \right)^2 \right] m_y^2 \\ m_Z^2 &= \frac{Z^2}{B^2 c^2} \sqrt{2} m_x^2 \end{aligned} \quad \dots (2)$$

by integrating (2) for the whole range of object space, we obtain

$$\begin{aligned} m_X &= \frac{Z}{c} m_x \\ m_Y &= \frac{Z}{c} m_y \\ m_Z &= \sqrt{2} \frac{Z}{c} \frac{Z}{B} m_x \end{aligned} \quad \dots (3)$$

These are the basic formulas usually used in the normal case to express the relationship of the accuracy of object space coordinates for the given object distance Z , the base B , and the camera principal distance c .

For the central point in object space, $X = \frac{B}{2}$, $Y = 0$, we obtain from (2)

$$\begin{aligned}
 m_X &= \frac{1}{\sqrt{2}} \frac{Z}{c} m_x \\
 m_Y &= \frac{1}{\sqrt{2}} \frac{Z}{c} m_y \\
 m_Z &= \sqrt{2} \frac{Z}{c} \frac{Z}{B} m_x
 \end{aligned}
 \quad \dots (4)$$

From equations (3) and (4), it can be seen that the least errors in the object space coordinates of points may be obtained when the object distance Z is a minimum, and the base B is a maximum. However, Z is a function of (1) the minimum range of the camera lens, (2) the depth of field of the camera lens, and (3) the size of the photo format, while B is a function of (1) the photo scale, (2) the photo format size, and (3) the overlap between the two photos. These factors, then limit the attainable accuracy of object space coordinates in the normal case. One way of further increasing the base and decreasing the object distance is by the introduction of convergence.

3- THE CONVERGENT CASE OF PHOTOGRAMMETRY

There has been a number of investigations to determine how accuracy is improved by the introduction of convergence. Except for the work of Abdel-Aziz and Karara (1974), researches that do introduce this convergence have tended towards directing the camera axes to the central point in object space. In this situation, the variation in object space coordinate accuracy as the amount of convergence is varied were studied. However, Abdel-Aziz and Karara (1974) have shown that for a fixed base-object distance ratio, if convergence is indeed introduced, directing the camera axes towards the central point yielded the least accuracy, so that they recommended that "the normal case be used, if possible, otherwise the angle of convergence must be kept as small as possible". It should be noted, however, that their conclusions was based on a fixed base-object distance ratio. But in introducing convergence, it should also be accepted that there is an accompanying decrease in the object distance and an increase in the base, provided that the same average photo scale and the same "equivalent overlap" are maintained.

4- The Equivalent Normal Case and the Equivalent Overlap

In Figure 2, we have a normal case with base B , object distance D , and the two convergent (symmetrical) cases with the corresponding base, object distance and convergence B'' , D'' , ϕ'' , and B''' , D''' , ϕ''' , respectively. All three cases have the same average photo scale. The normal case as shown is the equivalent normal case for both convergent cases. Thus from the relationships shown in Figure 2 it can be seen that although the base, the object distance, and the convergence are varying from one configuration to another, both convergent cases can be referred back to the same equivalent normal case. The overlap of the equivalent normal case is what we refer to as the "equivalent overlap". From an analysis of the equivalent normal case, we now define the overlap angle Θ as

$$\tan \Theta = \frac{B}{D} \quad \dots (5)$$

Θ will be a function of the photo format, the principal distance and the overlap of the equivalent normal case. Referring back to Figure 2, if

- S = photo format dimension parallel to the base
- c = principal distance
- D = object distance of equivalent normal case
- O = overlap of the equivalent normal case in %
- Θ' = one half of the field angle of the camera,

we have

$$\tan \Theta' = \frac{S}{2c} \quad \text{or} \quad \frac{S}{c} = 2 \tan \Theta'$$

In Figure 4, ϕ , α , and c are as in Figure 3. Also, m_{x1} , m_{y1} , m_{x2} , m_{y2} are the plate coordinate errors in the pseudo-normal photo, and m'_{x1} , m'_{y1} , m'_{x2} , m'_{y2} are the plate coordinate errors in the convergent photo. We now assume $m_{x1} = m_{x2} = m_x$, $m_{y1} = m_{y2} = m_y$ and $m'_{x1} = m'_{x2} = m'_x$, $m'_{y1} = m'_{y2} = m'_y$. Using the notations of Figure 4, we now introduce the formulae developed by abdel-Aziz and Karara (1974), which relate the plate coordinate errors in a convergent photo to those in a pseudo-normal photo, for the central point, as follows :

$$m_x = \frac{1 + \tan \alpha \tan \phi}{1 - \tan(\alpha - \phi) \tan \phi} \cdot m \quad \dots (6)$$

$$m_y = \frac{\sec \phi}{1 - \tan(\alpha - \phi) \tan \phi} \cdot m$$

Substituting (6) into (4) we obtain

$$m_X = \frac{1}{\sqrt{2}} \cdot \frac{D'}{c} \cdot \frac{1 + \tan \alpha \tan \phi}{1 - \tan(\alpha - \phi) \tan \phi} \cdot m$$

$$m_Y = \frac{1}{\sqrt{2}} \cdot \frac{D'}{c} \cdot \frac{\sec \phi}{1 - \tan(\alpha - \phi) \tan \phi} \cdot m \quad \dots (7)$$

$$m_Z = \sqrt{2} \cdot \frac{D'}{c} \cdot \frac{D'}{B} \cdot \frac{1 + \tan \alpha \tan \phi}{1 - \tan(\alpha - \phi) \tan \phi} \cdot m$$

From Figure 3, it can be shown that

$$\frac{1 + \tan \alpha \tan \phi}{1 - \tan(\alpha - \phi) \tan \phi} = \left(\frac{D}{D'} \right)^2 \quad \dots (8)$$

$$\frac{\sec \phi}{1 - \tan(\alpha - \phi) \tan \phi} = \frac{D}{D'}$$

Substituting (8) into (7), we obtain

$$m_X = \frac{1}{\sqrt{2}} \cdot \frac{D}{c} \cdot \frac{D'}{D} \cdot m$$

$$m_Y = \frac{1}{\sqrt{2}} \cdot \frac{D}{c} \cdot m \quad \dots (9)$$

$$m_Z = \sqrt{2} \cdot \frac{D}{c} \cdot \frac{D'}{B} \cdot m$$

Comparing equations (9) with equations (4), we note that the introduction of convergence

- 1- increases the error in X by the ratio D / D'
- 2- does not change the error in Y
- 3- decreases the error in Z by the ratio B/B'

From Figure 3, also, we have

$$D' = \left(D - \frac{B}{2} \sin \phi \right) \cos \phi \quad \dots (10)$$

$$B' = B \cdot \cos \phi + 2 D \sin \phi$$

Substituting (10) into (9), we obtain

$$\begin{aligned}
 m_X &= \frac{1}{\sqrt{2}} \cdot \frac{D}{c} \cdot \frac{D}{(D - 1/2 B \sin \phi) \cos \phi} \cdot m \\
 m_Y &= \frac{1}{\sqrt{2}} \cdot \frac{D}{c} \cdot m \\
 m_Z &= \sqrt{2} \cdot \frac{D}{c} \cdot \frac{D}{B \cdot \cos^2 \phi + 2D \cdot \sin \phi} \cdot m
 \end{aligned} \dots (11)$$

If we now substitute equation (5) into (11), we get

$$\begin{aligned}
 m_X &= \frac{1}{\sqrt{2}} \cdot \frac{D}{c} \cdot \frac{m}{(1 - 1/2 \tan \Theta \sin \phi) \cos \phi} \\
 m_Y &= \frac{1}{\sqrt{2}} \cdot \frac{D}{c} \cdot m \\
 m_Z &= \sqrt{2} \cdot \frac{D}{c} \cdot \frac{m}{\tan \Theta \cos^2 \phi + 2 \sin \phi}
 \end{aligned} \dots (12)$$

Since the positional error $m_T = \sqrt{m_X^2 + m_Y^2 + m_Z^2}$, we have

$$\begin{aligned}
 m_T &= \frac{D}{c} \cdot m \sqrt{\frac{1}{2(1 - 1/2 \tan \Theta \sin \phi)^2 \cos^2 \phi} + \frac{1}{2} + \frac{2}{(\tan \Theta \cos^2 \phi + 2 \sin \phi)^2}} \\
 m_T &= \frac{D}{c} \cdot m \cdot K \\
 K &= \text{Error Factor}
 \end{aligned} \dots (13)$$

Equation (12) and (13) can now be considered as the general formulas expressing the object space coordinate errors as a function of the plate coordinate error, m , the photo scale, c/D , the convergence, ϕ , and the overlap angle, Θ , for any symmetrical configuration. Since the photo scale is constant (assumption 1), analysis of different configurations reduced to studying the variation of the error factor as the overlap angle and the convergence are varied.

For example, the normal case is obtained when $\phi = 0$, i.e., zero convergence, and equations (12) become.

$$\begin{aligned}
 m_X &= \frac{1}{\sqrt{2}} \frac{D}{c} \cdot m \\
 m_Y &= \frac{1}{\sqrt{2}} \frac{D}{c} \cdot m \\
 m_Z &= \sqrt{2} \frac{D}{c} \cot \Theta \cdot m
 \end{aligned}$$

which are exactly the same as equations (4); since $\cot \Theta = \frac{D}{B}$. Equation (13) become

$$m_T = \frac{D}{c} \cdot m \sqrt{1 + 2 \cot^2 \Theta} = \frac{D}{c} \cdot m \cdot K \dots (14)$$

where Error Factor $K = \sqrt{1 + 2 \cot^2 \Theta}$ for normal case.

By definition $b = s(100 - o) / 100$

$$\tan \Theta = B / D = b / c = \frac{s(100 - o)}{100c}$$

or $\tan \Theta = \tan \theta (100 - o) / 100$

Table 1 shows the overlap angles for different camera field angles and different overlaps. We can now say that since the two convergent cases have the same equivalent normal case, they have the same equivalent overlap, therefore, the same overlap angle Θ .

Overlap (%)	20° Narrow Angle	40° Narrow Angle	60° Normal Angle	90° Wide Angle	120° Superwide Angle
100	0	0	0	0	0
90	2	4	7	11	19
80	4	8	13	22	34
70	6	12	19	31	46
60	8	16	25	39	54
50	10	20	30	45	60

Table 1. Overlap angles in degrees for different camera field angles and different overlaps.

5- Mathematical Formulas for Estimating Accuracy of Convergent Cases.

Before we derive the necessary formulae, we set the assumptions with which we shall compare one configuration with another. These assumptions are :

- 1- The average photo scale is constant from one configuration to another
- 2- The overlap angle is the same from one configuration to another
- 3- The optimum configuration, by definition, is attained when the positional error

$$m_T = \sqrt{m_X^2 + m_Y^2 + m_Z^2} \text{ is a minimum, i.e., Least positional error.}$$

In Figure 3, we have maintained the same average photo scale and the same overlap angle for both the normal and the convergent cases (assumptions 1 and 2). We assume, here, the symmetrical case so that $\phi_1 = \phi_2 = \phi$ and $\alpha_1 = \alpha_2 = \alpha$. In analyzing the convergent case, Abdel-Aziz and Karara (1974) developed formulae relating the plate coordinate errors of a convergent case and those of what they called a pseudo-normal case. Using the accepted relationship between object space coordinate errors and plate coordinate errors of the normal case, they were able to express, in turn, the object space coordinate errors in terms of plate coordinate errors of a convergent case. In effect, they reduced a convergent photo into a pseudo-normal photo. This reduction is illustrated in Figure 4.

For the special convergent case when the camera axes are directed toward the central point in object space, i.e., $\phi = \alpha$ and $\Theta = 0$, we obtain

$$m_X = \frac{1}{\sqrt{2}} \frac{D}{c} \sec \phi \ m$$

$$m_Y = \frac{1}{\sqrt{2}} \frac{D}{c} \ m$$

$$m_Z = \frac{1}{\sqrt{2}} \frac{D}{c} \csc \phi \ m$$

$$m_T = \frac{D}{c} \ m \sqrt{\frac{1}{2} \sec^2 \phi + \frac{1}{2} + \frac{1}{2} \csc^2 \phi}$$

$$m_T = \frac{D}{c} \ m \ K \quad \dots (15)$$

where Error Factor $K = \sqrt{\frac{1}{2} \sec^2 \phi + \frac{1}{2} + \frac{1}{2} \csc^2 \phi}$ for this case of convergent case of convergent configuration.

6-OPTIMUM CONFIGURATION

For the normal case, the best configuration, i.e. that one with the least positional error, is obtained, as mentioned earlier, by minimizing the object distance D , and maximizing the base B .

For the special convergent case where the camera axes are directed towards the central point in object space, the optimum configuration is obtained by minimizing m_T with respect to ϕ in equations (15), thus:

$$\frac{dm_T}{d\phi} = 0$$

and we obtain $\tan^4 \phi = 1$, or $\phi = 45^\circ$. This means that for this special case, optimum configuration is attained when the convergence is equal to 45° . Since equations (15) independent of the overlap angle, therefore independent of the camera field angle, this conclusion is true for any camera used.

For the general convergent case, we can similarly obtain the optimum configuration by minimizing m_T in equation (13) for any given overlap angle. Doing this is not a simple operation. Marzan (1975), instead solved for the values of the Error Factor in equation (13) for every degree of the overlap angle Θ , from 0° to 60° , and every degree of convergence ϕ , from 0° to 60° , and lists these values as a table. From his table, for a given overlap angle, the angle of convergence at which the Error Factor is a minimum is the convergence of the optimum configuration. Similarly, for a given convergence, the overlap angle at which the Error Factor is a minimum will also give the optimum configuration. From the table, it was noted that as the overlap angle increases, which means that the equivalent overlap, or the field angle of the camera, or both, is increasing, the convergence at which optimum configuration is attained decreases. The greater the camera field angle, therefore, the less is the introduction of convergence desirable. This, perhaps, may partially explain the fact that with the advent of the superwide angle camera, interest in using the convergent camera in aerial photogrammetry had slowly diminished.

As shown earlier, equations (12) are general and can be used to calculate the estimated object space coordinate errors for any configuration with its given overlap angle, convergence photo scale and plate coordinate error. Also, the equation can be used to design the configuration, i.e., determine the base, object distance and convergence that should be used in data acquisition in order to attain a certain required accuracy.

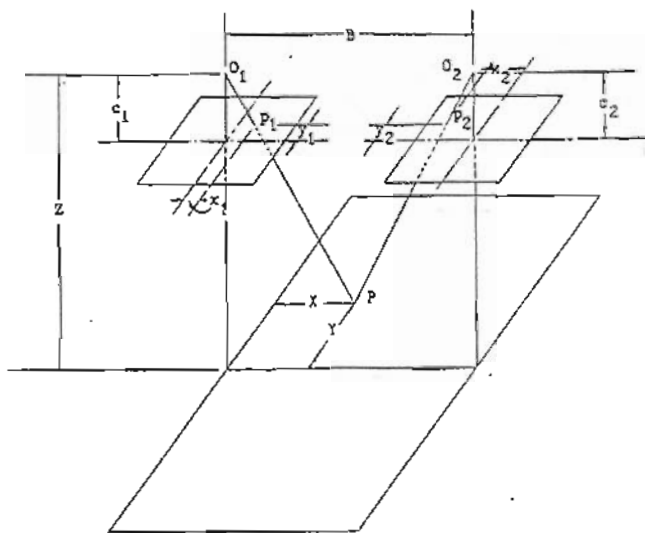

Figure 1. The normal case of photogrammetry

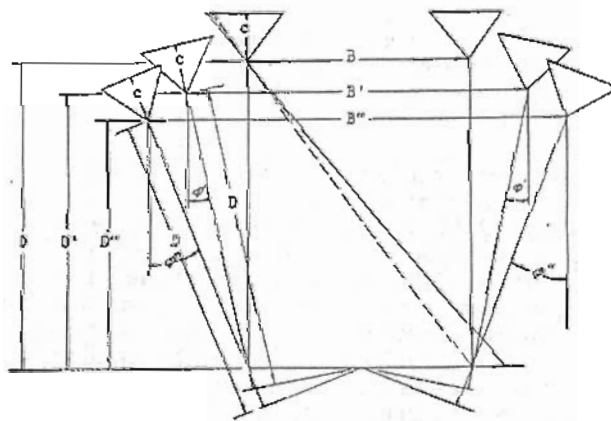

Figure 2 Convergent cases, equivalent normal case, and the overlap angle.

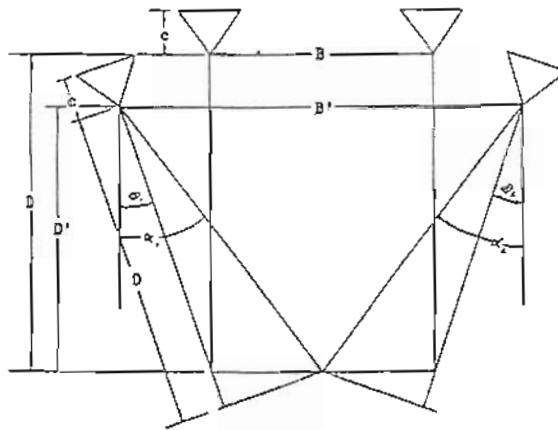

Figure 3. Relationship between normal and convergent (symmetrical) cases of photogrammetry with the same average photo scale and the same equivalent overlap.

- B - base for the normal case
- D - object distance for the normal case
- B' - base for the convergent case
- D' - object distance for the convergent case
- c - camera principal distance
- ϕ_1, ϕ_2 - angles of convergence of the two photos; angles which camera axes make with the direction perpendicular to the base.
- α_1, α_2 - angles which the lines joining central point of object space and perspective centers make with perpendicular direction to the base.

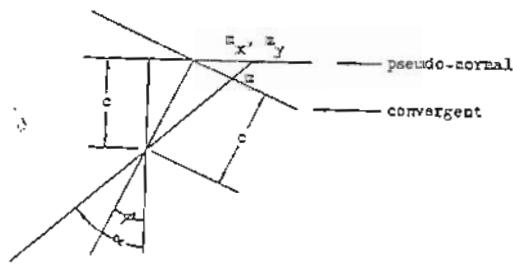

Figure 4. Reduction of a Convergent, Into a Pseudo-Normal, Photo.

REFERENCES

- 1- Abdel-Aziz, Y. I., and Karara, H.M. "Photogrammetric Potentials of Non-Metric Camera," Civil Engineering Studies, Photogrammetry Series No. 36, University of Illinois, March 1974.
- 2- Faig, W., and Moniwa, H. "Convergent Photos for Close Range," Photogrammetric Engineering XXXIX, 6, June 1973.
- 3- Gruner, H., Zulqar-Nain, J., and Zander, H. A. "A Short Range System for Dental Surgery," Photogrammetric Engineering, XXXIII, 11, November 1967.
- 4- Karara, H.M., and Abdel-Aziz, Y.I. "Accuracy Aspects of Non-Metric Imageries," Paper Presented at the ASP/ACSM 1973 Fall National Convention, Orlando, Florida.
- 5- Kenefick, J.F. "Ultra-Precise Analytical Stereotriangulation for Structural Measurements," Proceedings of the ASP/UI symposium on Close-Range Photogrammetry, Urbana, Illinois, 1971
- 6- Malhotra, R.C., and Karara, H.M. "High Precision Stereometric System," Civil Engineering Studies. Photogrammetry Series No. 28. University of Illinois, 1971.
- 7- Marzan, C. T. "Rational Design For Close Range Photogrammetry," Thesis, University of Illinois, Urbana-Champaign, 1975.