

Menoufiya University  
 Faculty of Engineering  
 Shebin El- Kom  
 Second Semester(June) Examination  
 Academic Year: 2013-2014  
 Date: 14/6/2014



Dept.: Production Engineering  
 Year : Post-Graduate Diploma  
 Subject: Planar Kinematics of  
 Multiple Rigid Bodies  
 Code : BES521  
 Time Allowed: 3 hours  
 Total Marks : 100 Marks

Allowed Tables and Charts: None  
 Examiner: Dr/ Mohamed Hesham Belal.

**Answer All The Following Questions:**

**Question No.(1):**

[ 20 Mark]

For the 3-DOF (RRP) SCARA arm of a manipulator shown in Fig.(1) .

- 1- Assign frames and tabulate the joint-link parameter,
- 2- Determine the transformation matrices relating successive links,
- 3- Obtain the orientation and position of the end-effector relative to the base,
- 4- Check the correctness of the results and describe it at the home position,
- 5- Compute the orientation and position of the end-effector if the joint variable vector is  $q = [60^\circ \ 120^\circ \ 20 \text{ cm}]^T$  with  $d_1 = 10 \text{ cm}$ ,  $a_1 = 50 \text{ cm}$ ,  $a_2 = 30 \text{ cm}$ .

**Question No.(2):**

[ 20 Mark]

Derive the Hamilton's canonical equations of the shown system in Fig.(2).  
 All data are given.

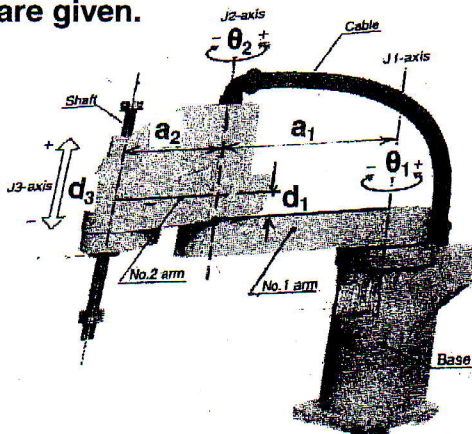

Fig.(1)

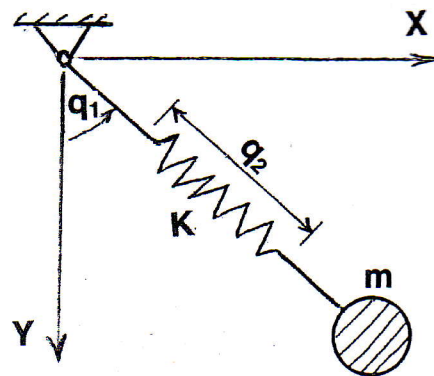

Fig.(2)

**Question No.(3):**

[ 20 Mark]

A cantilever of flexural rigidity  $EI$ , length  $L$  and mass per unit length  $\rho$  performs a transverse vibration. If the free end of the beam is fastened to a motor of mass  $m$  as shown in Fig.(3), derive the frequency equation of the present continuous system.

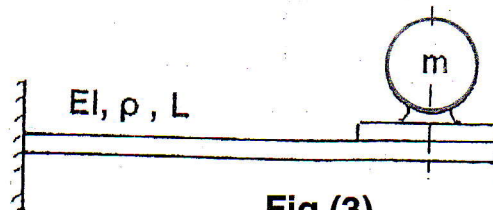

Fig.(3)

**Question No.(4):**

[ 20 Mark]

Consider the stepped bar shown in Fig.(4), when its free end is subjected to the axial load  $F = 500$  N. The bar has the following data:

$$E_1 = E_2 = 2 \times 10^{11} \text{ N/m}^2, \quad \rho_1 = \rho_2 = 7.8 \times 10^3 \text{ kg/m}^3$$
$$A_1 = 2A_2 = 20 \text{ cm}^2, \quad L_1 = L_2 = 80 \text{ cm}.$$

Use the finite element technique to obtain the natural frequencies and plot the corresponding mode shapes.

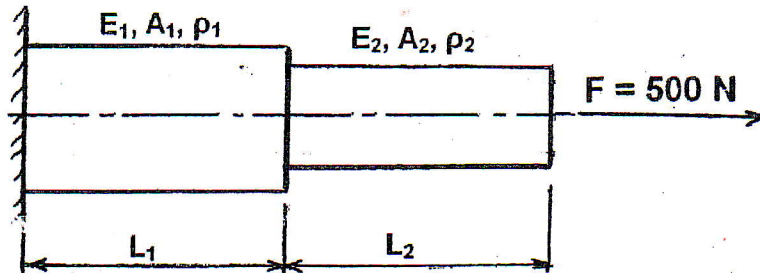

Fig.(4)

**Question No.(5):**

[ 20 Mark]

A marine propulsion is shown in Fig.(5). For the analysis of torsional vibration, the installation can be modeled as the system shown, where the mass moments of inertia for the engine, gearbox, and propeller taken about the axis of rotation are  $I_E, I_G,$  and  $I_P$  respectively, and the stiffnesses of the gearbox and propeller shafts are  $K_G$  and  $K_P$  respectively. If damping can be neglected, the numerical values are:

$$I_P = 5I_G = 2.5 I_E = 2.0 \text{ kg.m}^2, \quad K_G = 3 K_P = 360 \text{ kN.m/rad},$$

- (a)- Derive in matrix form the differential Equations governing the torsional vibration of the system,
- (b)- State whether the system has rigid body mode. Give reasons.
- (c)- Calculate the natural frequencies and corresponding mode shapes, and give the position of the node for each frequency.

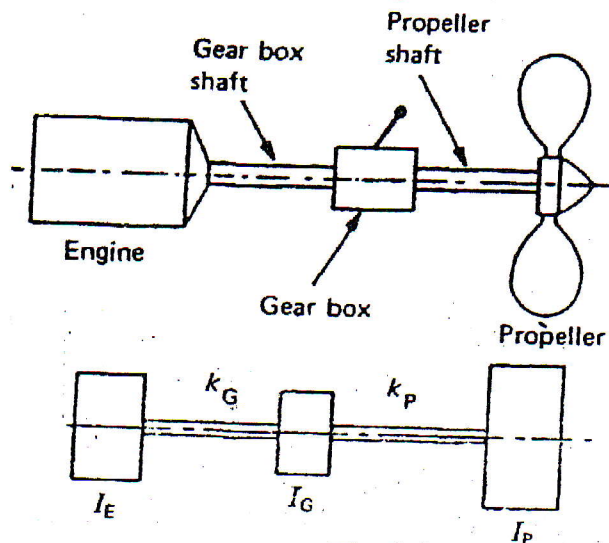

Fig.(5)

*With my best wishes*