

Development of a local steel track of the rice harvester for harvesting wheat crop

Shalabey, S.A.M.

Agric. Eng. Res. Inst., (AERI), Giza, Egypt

ABSTRACT

The main objective of this research is to maximize utilization capacity of the Japanese rice combine for harvesting other crops by developing and equipping a local manufactured steel track instead of the original rubber track. The key development considerations of the harvester traction device are intended to the poor mobility and castle age of rubber tracks during harvesting wheat crop on rough terrains soil conditions. The traction performances of the developed steel track were investigated and compared to the traction performances of the original rubber track versus four different harvesting forward speed of; 0.39,0.50,0.72,0.94 m/sec, and two motion states; namely straight line state and curve state. The evaluation and comparisons parameters included:- track rolling resistance, track slip ratio, dynamic traction ratio, the harvester tractive force, traction efficiency, actual field capacity, fuel and energy consumption and the harvester operational costs.

The results showed in general that the local manufactured steel track supply the greatest solution where there are tough soil terrains during wheat harvesting. The optimum proper developing parameters of the local steel track were contact length of 0.97 m, width of 0.30 m and weight of track of 0.89 kN. While optimum operation conditions as the combine harvester was equipped with the developed track were obtained at operating forward speed of 0.72 m/sec Whereas the following results were obtained:-highest traction efficiency of 83.1%, highest dynamic traction ratio of 78.1%, lowest rolling resistance of 1.99 kN, maximum pull force of 15.01 kN, traction force ranged from 13.5 to 20.1 kN at ranged slip ratio from 4.1 to 6.2%, average field capacity 0.89 fed/h, fuel consumption of 8.1 L/h. It was found that the total profit by wheat harvesting season increased 9% compared to the combine performance when equipped with the rubber track and the total cost (price) of manufacturing one steel track is about 1750 LE.

INTRODUCTION

The Japanese type combine harvester is primarily used to harvest rice crop in paddy fields on soft ground. Therefore, these machines are equipped with rubber tracks and so that the mean ground contact pressure is as low as possible, it is ranged from 15 to 25 kPa (0.15-0.25 kgf/cm²). Therefore, the main objectives of this research is to maximize utilization of the Japanese combine harvester by developing a local steel track to harvest wheat and soybean crops in dry and rough soil conditions.

Ito (1987) observed that there are two ways of reducing the turning resistance by decreasing the contact area if tracks; to decrease the width of the braked track and to shorten its contact length during turning motion. The latter method was easier to control and reduced the turning resistance force by 20 % when the braked track was pivoted at its center .He also observed that when both tracks were pivoted under the turning motion, the turning resistance was reduced by 50 % .

Abou-Elmagd,(2002) compared and evaluated the maneuverability of three ground-drive devices, the crawler, pneumatic tire, and steel lug wheel

types within straight-line and angled traffic passes in the Egyptian rice field. The results summarized that the crawler was less lugging ability and more damaging the soil at the rice field boundaries. The average propelling resistance of the angled pass exhibited of about 1.1-1.16 times that propelling resistance of the straight-line motion.

Frank, (2012) stated that the steel tracks are well-known for their longevity and prolonged existence, and many specialists really feel that do not put on off with time like their rubber counterparts. They also deal with stress with much more performance however it can not be denied that they make more noise than the rubber types. The noise functions like a warning sign and makes individuals mindful that you are coming in close proximity to, and thus supplying them enough time to shift. The rubber tracks are much more chosen decision for pavements simply because they are easier to transfer on the concrete finishes, but when there are muddy roads, rocks, and bushes, steel tracks are a far better choice. If you are doing work in a spot in which there are no tough terrains then you might undoubtedly decide for rubber tracks.

Robert *et. al.* (2011) reported that Rolling resistance is the force required to keep on object such as a wheel, a tire or a track moving, at a constant speed, the rolling resistance force is equal to the traction force between the road and tire. The torque turning the tire then balances with the moment or torque created by the traction force. Forces contributing to the rolling resistance include:-

- 1- Friction losses at the rolling interface due to slip,
- 2- Friction in the bearings (internal), and
- 3- Hysteric losses due to deformation of the rubber as results of the fluctuating stresses and strains induced in the rubber track during rolling as the peaks comes in and out of contact with the road. The rolling resistance coefficient is determined by dividing rolling resistance by normal load. An ideal rigid cylinder or wheel rolling with no slip against a perfectly smooth, level and rigid surface would have no rolling resistance.

Caliguiran (2014) reported that the rubber tracks are not suitable for the rice fields in the Philippine country. However, when the machine gave-up, they can not find spare parts at the local market. Their new harvester has now a metal track. They had also adjusted some of the parts to suit the requirements of the Japonica rice. Prior to the purchase of this imported boom type harvester from Thailand, the company bought first five Japanese brand harvesters, however. Before harvesting their Japonica rice, they make sure that the grains have 22 to 25 percent moisture content. The Phattana combine harvester can harvest 4 hectares in 6 hours and operated by one person. The harvester will then unload the grains into a dump truck with a capacity of 50 to 60 bags.

Therefore, the aim of the present study is to manufacturing a local steel track for the rice combine harvester in order to harvest other crops in dry and rough soil surface like wheat crop. Thus, the objects treated by this study can be grouped broadly in two categories:-

- 1-Engineering measurements; including verify the difference between the two tracks types in weight, length and width to compare between the two contact areas.
- 2-Field experiments to compare and evaluate the developed and the original tracks under different variables of, four traveling speeds, V; two different motion states and two types of tracks, steel track Str and rubber track, Rtr

]

MATERIALS AND METHODS

1- Materials:

To fulfill the objectives of this study, a Japanese combine harvester was equipped two separated times with the two different types of tracks; one time with the original rubber track and the second time with the manufactured metal track. The technical specifications and operating parameters of the combine and its rubber track are shown in Table (1) and Table (2),

Table (1): Technical specifications and operating parameters of the combine

Items and names				Specifications
Model				R₁-43-U-E
Dimensions	Overall length (with cutter)		mm	4255
	Overall width		mm	1827
	Overall height		mm	2040
Weight	kN			19.41 including grain weight
Engine	Type			Kubota diesel engine
	Output/speed		Kw/rpm	32.25/3000
Traveling section	Crawler (width × ground length), mm			400×1310
	Average ground pressure N/cm ²			1.85
	Travelling Speed m/s	Forward	Reaping	Starting rice/wheat 0 to 1.22, loading rice 0 to 0.86
			Transporting	0 to 1.65
		Backward	Transporting	0 to 1.65
Reaper	Reaping width mm			1450
Grain outlet	Hopper	Grain taking-out system		Hopper type, 3 bags
		Capacity (bag)		4

The original rubber track was mainly designed and made as shown in Fig. (1 - a) to work on wet surfaces, these investigations show that this track

is not qualified to work on the wheat dry fields due to the big differences between the two types of soil structures.

To overcome all problems affecting the combine performance on wheat field conditions, the original rubber track was replaced by the local manufactured steel track and then the pre-experimental adjustments for the steel track was done.

The specifications of the used steel materials are shown in Table (3) as disassembled, while the assembled track is shown in Fig. (1 - b) and its specifications are tabulated in Table (4).

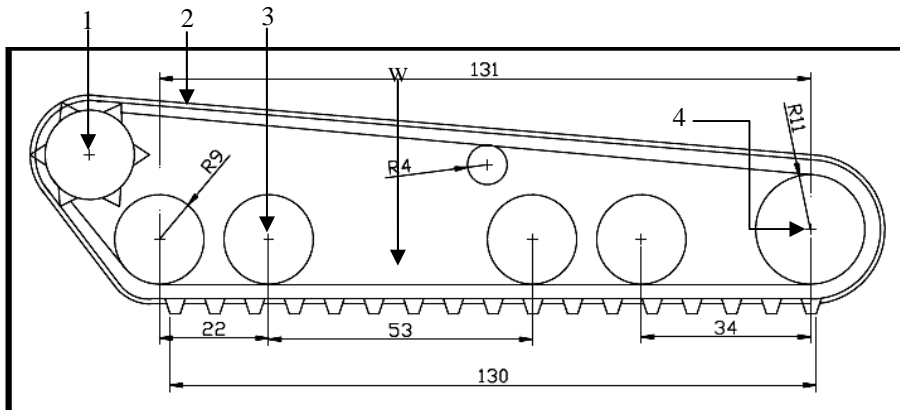

Fig (1-a): Sketched view of the rubber track

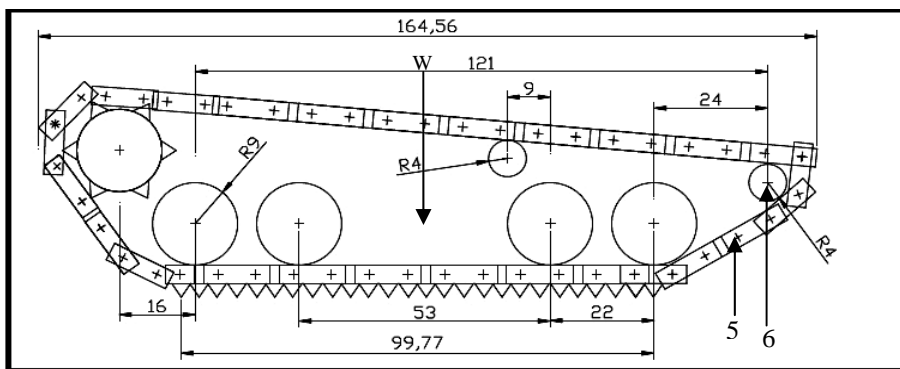

Fig.(1-b); Sketched view of the steel track

1- sprocket wheel, 2- rubber track, 3- roller, 4- original idler, 5- steel track, and 6- the modified idler

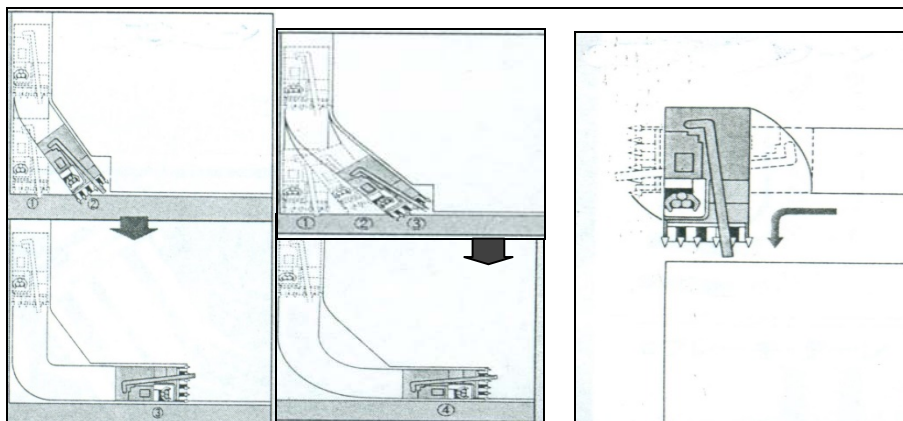

Fig (3 - a): The combine behavior with the steel track while turning

Fig (3-b): The combine behavior with rubber track while turning

Table (2): Specifications of original rubber track and traction device

Item and name	Unit	Rubber track
Length of contact rubber track	mm	1310, in both rice and wheat field
Width of contact rubber track	mm	400 in case of rice field, and 300 in case of wheat field
Road wheel No., metal		4 + idler wheel
Road wheel diameter	mm	160
Distance between road wheels/ Idler	mm	220 – 530 – 220/340
Radius of sprocket (Inner/outer)	mm	160/250
Sprocket teeth No.		6
Idler diameter	mm	220
Road wheel pitch	mm	40 + 40
Total number of peaks (stripes), rubber		42
Contact area of one peak, rubber	mm ²	20 × 300 = 6000
Number of peaks on contact area 2 tracks		$\frac{1310 \times 2}{82.5} = 15.87 \times 2 = 16 \times 2 = 32$
Total contact area in wheat field	mm ²	192000
Weight of track, (rubber)	kN	0.88
Specific ground pressure	N/ cm ²	0.45

Table (3): The components of the steel track disassembled

Table (4): The descriptions of the metal track

Items and names	Units	Steel value
Length of contact metal track	mm	970 in case of dry field
Width of contact metal track	mm	300
Number of peak (strips), metal		$20 \times 3 = 60$
Width of one peak	mm	≈ 25
Total length of peak across	mm	$(40 \times 6) + 60 = 300$
Total contact area of one peak	mm ²	7500
Number of peak on contact area for 2 tracks		$(970/150) \times 3 \times 2 = 19 \times 2 = 38$
Total contact area	mm ²	$38 \times 7500 = 285000$
Weight of one track	kN	0.89
Specific contact- ground pressure	N/cm ²	0.31

a. Pre-experimental adjustments

The local steel track was designed to be shorter than the original in both length and width of the contact area in order to reduce the turning resistance by forming a small pivot area, as shown in fig.(1-b), so that the idler of the traction device was modified by reducing its radius dimension to be (12 cm) instead of (22 cm). While the original rubber track was designed to contact with the wet or dry soil surface in rice or wheat fields at full length of (1310 mm.) and full width of (400 mm.). The combine behaviors while turning motion is shown in figure (3-a) when equipped with the rubber track and shown in figure (3-b) when equipped with the steel track.

b. Engineering specifications measurements

The engineering measurements of the main dimensions of the local metal track; weight, length and width of each element were done for the track before assembling. These measurements were done also for the assembled track at the workshop of the Gemmeiza Research Station.

c. Soil physical properties measurements

The physical properties of the soil were measured and summarized in Table (5)

Table (5):- The physical properties of experimental soil

Fine sand	Course sand	Silt	Clay	Clay rate	Soil texture	humidity
14.70	0.66	40.81	43.83	0.78	clayey	13.5% w.b

d. Variables parameters

1-Four different combine harvesting speeds, $V_1=0.39$, $V_2=0.50$, $V_3=0.72$ and $V_4=0.94$ m/sec

2-Two different combine motion states; straight line and turning curve.

3-Two types of tracks; The original rubber track type (Rtr) and the developed steel track type (Str)

2- Methods:

1- Track traveling speeds: (V)

To measure the track forward speed during the experimental work; a mark was fixed on the track periphery and another mark was fixed onto the soil surface. During the combine movement a stop watch used to determine the travelling time (t) for three complete revolutions of the track. Then the distance (d), which represents the linear travelled distance was measured.

The track forward speed (V) could be determined by dividing the distance (d) by the time (t) according the following equation:

$$v = \frac{d}{t} \quad (1)$$

Where:-

- V = combine forward speed, m/s,
- d = travelling distance covered, m and
- t = travelling time

2- Track slip percent, (S):-

Function of combine load, track surface condition and travel speed, the slip ratio was calculated using the following equation:-

$$S = \frac{D - d}{D} \times 100 \quad (2)$$

Where:-

- S = percent of track slip %,
- D = periphery of track for 3 times, m and
- d = the actual travelling distance for 3 revolutions of track on the field

3- Tractive force determination:- (F)

To determine the draft of harvesting operation (tractive force), a hydraulic dynamometer was placed in between the combine harvester and a 4 WD tractor in front of the combine. The gear of the combine was kept in neutral position while towing before 20 meters by the end of trace, the reading of the hydraulic dynamometer was recorded. Each run was repeated 3 times. The draft force was calculated using the following calibration equation of the system:-

$$F = 0.38 X - 0.25 \quad (3)$$

Where:-

- F = gross thrust force acting on the wheel, kN,
- x = the reading of the hydraulic dynamometer in bar

4- Rolling resistance determination:- (R)

The rolling resistance of the combine traction device was measured by the same hydraulic dynamometer connected in between the 4 WD tractor while towing the combine harvester without loading and the combine gear was in neutral position. The reading of the dynamometer was recorded for each run and repeated 3 times.

5- Calculation the net useful pull force (P):-

The pull, (p) is the horizontal force at the combine axle generated by the driven sprocket wheel; it can be calculated as follows:-

$$\text{The pull force (P) = tractive force (F) – Rolling resistance (R)} \quad (4)$$

6- The dynamic traction ratio (traction coefficient ratio) (Tco):-

$$Tco = \frac{P}{W} \quad (5)$$

Where:-

W = weight of combine kN

7- Calculation of the tractive efficiency (Tef):-

The tractive efficiency was calculated using the following equation, (Barger *et al.*, 1979)

$$Tef = \frac{P}{P+R} (1-s) \quad (6)$$

Where:-

- Tef = tractive efficiency; %,
- P = pull force; kN,
- R = rolling resistance; kN and

S = slip % (decimal)

8- Engine power requirements (EPR):-

$$EPR = \left[F_c \times \frac{1}{3600} \right] \times \rho_f \times L.C.V \times 427 \times \mu_{th} \times \mu_m \times \frac{1}{75} \times \frac{1}{1.36} \quad (7)$$

Where:-

- EPR = power requirement; kW,
- F_c = fuel consumption rate; L/h,
- ρ_f = density of the fuel (for diesel fuel = 0.85 kg/L),
- L.C.V = lower caloric value of fuel kcal/kg; (10⁴ kcal/kg for diesel),
- 427 = thermo-mechanical equivalent; kg.m/kcal,
- μ_{th} = thermal efficiency of the engine (assumed to be 40% for diesel engine), and
- μ_m = mechanical efficiency of engine (assumed to be 80% for diesel engine)

9- Specific energy consumption (SEC):-

$$SEC = \frac{EPR}{A_{f,c}} \quad (8)$$

Where:-

- SEC = specific energy; kW.h/fed,
- EPR = power required; kW, and
- A_{f,c} = actual field capacity fed/h

10- Calculation of field capacity (fed/h)

The theoretical field capacity (T.F.C) was calculated using the following formula:-

$$T_{fc} = \frac{V \times wd}{4.2} \quad \text{fed/h} \quad (9)$$

Where:-

- T_{fc} = theoretical field capacity ; fed/h,
- V = forward speed; m/s, and
- wd = the actual working width; m

While the effective field capacity (Efc) was determined as follows:-

$$E_{fc} = \frac{1}{T} \quad \text{fed/h} \quad (10)$$

Where:-

- E_{fc} = effective field capacity ; fed/h, and
- T = the total time; h

RESULTS AND DISCUSSION

In order to evaluate the performance of the local steel track compared to the original rubber track on the dry soil conditions, many experiments were carried out while harvesting operation of wheat crop and the ranges of both forward speeds, track slippage ratios, rolling resistance and draft forces were measured.

The trends of the tractive performance such as the traction efficiency, the dynamic traction ratio and the pull force were calculated. Otherwise, the economic evaluation was done according the data of field capacity, fuel consumption and the track price cost.

1- Effect of the tested factors on both traction efficiency and dynamic traction ratio

The data plotted in Fig. (4) shows that the traction efficiency (Tef) of the developed steel track is higher than that of rubber track at the same track slip (s)% value. For example; at the slip ratio of 6.0% the traction efficiency values were 83.0% and 64.0% for the steel and the rubber track respectively, while the maximum traction efficiencies which represent the maximum performance of both tracks are 83.0% and 74.0% for the steel track and the rubber track respectively. These values occurred at track slip of 6.0% and 9.0% respectively. The data shows that traction efficiency values are increased considerably as the track slip increased. The data also shows that the traction coefficient (Tco) values (the dynamic traction ratios) of both steel track and rubber track increased considerably between 2.0% to 7.0% track slip ratio and then the increment rate was very limited. The maximum traction coefficient values at which the maximum traction efficiencies for both steel track and rubber track were 78.0% and 69.0% respectively, these values were occurred at slip ratios of 6.0% and 9.0% respectively.

2- The relationship between the traction efficiency, the track slip and draft force

As shown in Fig. (5) the traction efficiencies values of both steel and rubber tracks increase at reduced rate as the draft force values increased to approach the optimum traction efficiency values of 83.0% and 74.0% for the steel track and rubber track respectively, then, the values are decreased. The increment occurred because the gain in the draft power caused by the increase in the draft force was greater than the reduction in power caused by the track slip. After the optimum values of draft force controversy occurred, then the traction efficiency values decreased. Both optimum values of traction efficiencies occurred at draft force value of 17.0 kN but at track slip ratios of 6.0% and 9.0% for the steel track and the rubber track respectively which caused the difference between the optimum values of the traction efficiency.

3- The draft force ranges at which steel and rubber tracks operate at the maximum traction efficiency

The draft force ranges at which steel track and rubber track operates at the maximum traction coefficient (the maximum dynamic traction ratio) could be found in figure (5). By projecting the maximum values of the traction

which were obtained from figure (4) on the traction efficiency-draft force curves of both steel and rubber tracks in figure (5);

From the interest points A, B and A1, B1 at figure (5); there are two lines are drawn vertically to meet the draft force axe at C, D, C1, and D1 for rubber track and steel track respectively. Therefore, the draft force ranges which exist between these points are 13.5 – 20.0 kN and 12.75 – 20.50 kN for rubber track and steel track respectively. The track slip at which these draft force ranges occurred within are 7.0 – 9.0 % and 4.0 – 6.0 % for rubber track and steel track respectively. These results mean that the combine harvester with the steel track can operate at wider range of draft force within the maximum traction efficiency and this is regarded advantage for the steel track on the rubber track. These results due to 1- the power loss of steel track because of track slip is lower than that of rubber track as it can be seen from the ranges of the track slip. 2- the amount of specific ground pressure of the combine which becomes greater in case of steel track (0.31N/cm²) than in case of rubber track (0.45 N/cm²) as shown in Tables (2) and (4). Which increases the soil strength and then the soil thrust underneath the traction device. 3- the hysteric losses due to the rubber deformation as a result of the fluctuating stresses and strains induced in the rubber track peaks during the rolling as the peaks come in and out of contact area with the road

4- Effect of combine forward speed on both pull force and rolling resistance force

The data plotted in figure (6) shows that the values of pull force (for both steel and rubber tracks) increased as the value of the combine forward speed increased. The main reason of this increase is the decrease of the rolling resistance values at the same time for both steel and rubber tracks. The data also shows that the lowest values of the rolling resistance were recorded when the forward speed reached the amount of 0.72 m/s forward speed for both steel and rubber tracks. It means that this value of combine forward speed is the optimum value. The data also shows that the lower value of rolling resistance of 1.99 kN was recorded for the steel track, while the higher value of 3.18 kN was recorded for the rubber track when the combine forward speed approached the value of 0.72 m/s. It can be seen that the highest values of rolling resistance of 4.74 kN and 3.95 kN for rubber and steel tracks respectively were recorded at the same value of forward speed of 0.72 m/s. The superiority of the steel track on the rubber track was due to the

value of specific weight of the combine (N/cm²) while using the steel track which is greater than the value in case of using the rubber track, as shown in Tables (2) and (4).

5- Effect of combine forward speed on both field capacity, fuel consumption and energy requirement

The effect of turning curve motion state at the end of every harvesting trace as a treatment parameter is very clear at the measurement of turning time and turning curve distance which affect the field capacity (fed/h) and then the fuel consumption (L/h) and energy requirements (kW.h/fed) as shown in figures (3-a and b).

5-1. Effect of combine forward speed on field capacity:

The tabulated results in Table (6) show that the increase in forward speed of the combine translated to increment in field capacity. While increasing forward speed from 0.39 to 0.50 m/s the field capacity increased from 0.47 to 0.61 fed/h and from 0.44 to 0.57 fed/h for the usage of steel track and rubber track respectively. The same trend was occurred while increasing the forward speed from 0.50 to 0.72 m/s where the field capacity increased from 0.61 to 0.89 fed/h and from 0.57 to 0.83 fed/h for the usage of steel track and rubber track respectively. Then, while increasing the forward speed from 0.72 to 0.94 m/s the field capacity decreased from 0.89 to 0.87 fed/h and from 0.83 to 0.80 fed/h for the usage of steel track and rubber track respectively. The later results occurred because the increase in forward speed over 0.72 m/s lead to accumulate of the wheat stems. Consequently, increase of harvesting trouble and lost time. Thus, the optimum forward speed at which the maximum field capacity was occurred is at 0.72 m/s. for both steel or rubber track.

5-2. Effect of combine forward speed on both fuel and energy consumption:

As shown in Table (6), it is remarkable that while increasing the combine forward speed from 0.39 to 0.50 m/s, the amount of fuel consumption and energy requirements were decreased from 10.0 to 9.0 L/h and from 11.5 to 10.5 L/h fuel consumption and from 67.23 to 46.62 kW.h/fed and from 82.59 to 58.21kW.h/fed energy requirement while usage of the steel track and rubber track respectively. As the combine forward speed increase from 0.50 to 0.72 m/s, both of the fuel consumption and energy requirements were decreased from 9.0 to 8.0 L/h and from 10.50 to 10.0 L/h fuel consumption and from 46.62 to 28.40 kW.h/fed and from 58.21 to 38.07 kW.h/fed energy consumption while usage of the steel track and the rubber track respectively. Increasing the combine forward speed from 0.72 to 0.94 m/s the fuel consumed and energy required increased from 8.0 to 11.0 L/h and from 10.0 to 12.5 L/h fuel consumption and from 28.40 to 39.95 kW.h/fed and from 38.07 to 49.37 kW.h/fed energy requirement while usage of steel track and rubber track respectively. The later results occurred because of increasing the forward speed leads to accumulate of the wheat stems consequently, increase of the harvesting troubles and lost time. Therefore, it is necessary to adjust the forward speed to obtain the minimum fuel consumption and minimum energy requirement. This was obtained at the amount of forward speed of 0.72 m/s. So that, this amount of forward speed

is the recommended to obtain the highest field capacity and lowest fuel consumption and energy requirement while the usage of the steel track or rubber track.

Table (6): Effect of combine forward speed and turning time on both field capacity (fed/h), fuel consumption (L/h) and energy consumption

Forward speed m/s	Actual field capacity (fed/h)		Fuel consumption (L/h)		Power requirement (kW)		Energy consumption (kW.h/fed)	
	Steel track	Rubber track	Steel track	Rubber track	Steel track	Rubber track	Steel track	Rubber track
0.39	0.47	0.44	10.00	11.50	31.60	36.34	67.23	82.59
0.50	0.61	0.57	9.00	10.50	28.44	33.18	46.62	58.21
0.72	0.89	0.83	8.00	10.00	25.28	31.60	28.40	38.07
0.92	0.87	0.80	11.00	12.50	34.76	39.50	39.95	49.37

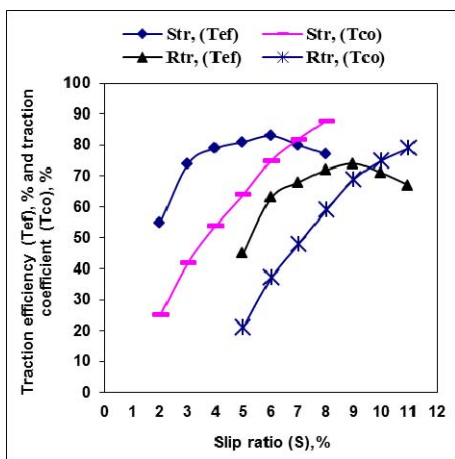

Fig (4): Effect of slip (S) % on both traction efficiency (Tef) % and traction coefficient (Tco) % in

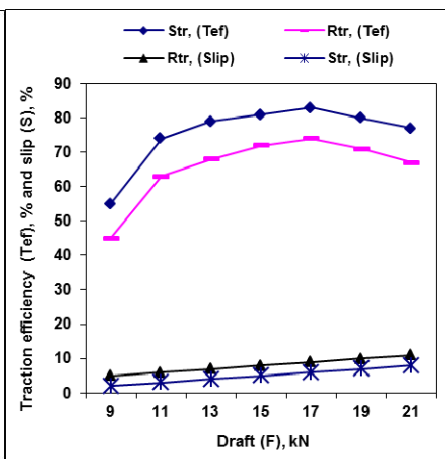

Fig (5): Effect of draft force (F) kN on both traction efficiency (Tef) % and slip (S) % in straight line

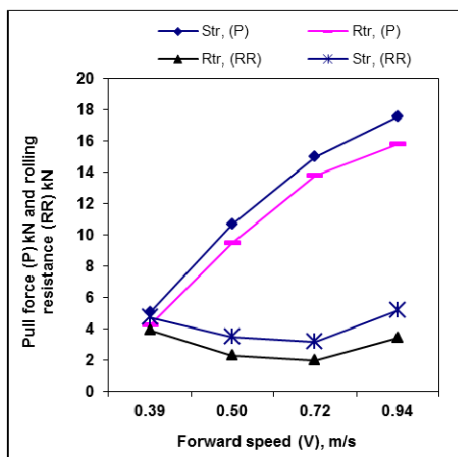

Fig (6): Effect of forward speed (V) on both pull force (P) kN and rolling resistance force (RR) kN in straight line

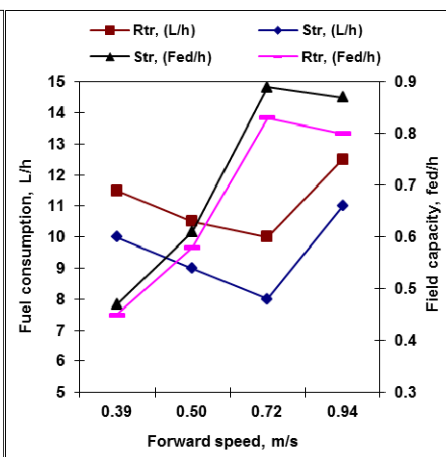

Fig (7): Effect of forward speed (V) on both field capacity (fed/h) and fuel consumption (L/h) in both two motion states

The obtained results showed the superiority to use the Japanese combine equipped with the local steel track to harvest other crops like wheat or soybean crops where as dry and rough soil conditions. The optimum values of the operation conditions were obtained at operating forward speed of 2.6 km/h (0.72 m/sec) and length of track contact area of about 0.97 m, width of about 0.30 m and weight of the steel track of 0.89 kN. Whereas given the best results of the highest traction efficiency of 83.1%, dynamic traction ratio of 78.1%, lowest rolling resistance of 1.99 kN, maximum pull of 15.01 kN, and traction force ranged from 13.5 to 20.10 kN at ranged slippage ratio from 4.1 % to 6.2%, actual field capacity of 0.89 fed/h, fuel consumption of 8.1 L/h. It was found that the total profit by wheat harvesting season (when equipped with the steel track) increment of 9% compared to the combine performance (when equipped with the rubber track) and the total cost (price) of manufacturing one steel track is about 1750LE.

REFERENCES

Abou-Elmagd, A.E. (2002): Comparative maneuverability of three ground drive devices under Egyptian rice field conditions. *J. Agric. Sci. Mansoura Univ.*, 27 (9):6345-6360.

Barger E.L., J.B. Liljedahi; W.M. Carleton and E.G. Mckibben (1979): *Tractors and their power units* publisher. John Wiley Sons. New York. ISBN; 0471019054

Caliguiran, V. B. (2014): Increasing farm efficiency through farm mechanization. *PhilMich (Philippine center post harvest development and mechanization)* 10/15/2014

Frank (2012) Rubber tracks vs. steel tracks. (www.hxrt.com.au) posted on February 23, 2012.

- Ito N. (1987): Practical method of reducing turning motion resistance of tracked vehicles. Journal of Terramechanics, 24(4): 251-261. Presented at the first Asian-Pacific Conference of I.S.T.V.S., Beijing, China, August 1986; 2 ref.
- Robert, L.J.; J. Richard Willis and Michael Arnold (2011): Synthesis of the effects of pavement properties on tire rolling resistance. NCAT Report, at Auburn University; 277 Technology Parkway – Auburn, Al 36830, 11-05

تطوير كتينة حديد محلية لآلة حصاد الأرز لتلائم حصاد محصول القمح سمير عبد الحميد شلبي معهد بحوث الهندسة الزراعية – الدقي – الجيزة

يعتبر محصول القمح من المحاصيل الإستراتيجية في مصر والعالم. وتعتبر عملية حصاد القمح من العمليات المكلفة لحاجته لأعداد كبيرة من العمالة ولزيادة نسبة الفاقد عند حصاده يدويا. يهدف هذا البحث إلى تطوير كتينه حديدية مصنعة محلياً لتحل محل الكتينة الكاوتش المخصصة أساساً لحصاد محصول الأرز في ظروف رطوبة. وقد تم تصنيع الكتينة بخامات محلية في ورشة محطة البحوث الزراعية بالجميزة – غربية، كما تم تحديد المواصفات الهندسية بعد التصنيع في الورشة الهندسية بحيث يكون الجزء الملامس لسطح الأرض طوله حوالي 97 سم وعرضه حوالي 30 سم مع الاحتفاظ بنفس عدد لنكات الكتينة الكاوتش 42 لنك ونفس الوزن 91 كجم. وتمت التجارب الحقلية في موسم حصاد القمح 2014 في المزرعة البحثية بمحطة البحوث الزراعية بالجميزة – غربية – اشتملت الدراسة على تقييم تأثير أربع مستويات للسرعة الأمامية للكومباين وهي 0.39 و 0.50 و 0.72 و 0.94 م/ث وكذلك تأثير اتجاهين للحركة – الأول: اتجاه الحصاد في خط مستقيم. والثاني: اتجاه دوران في منحنى بدون حصاد عند نهاية كل جرة – على خواص الشد للكومباين عند تركيب نوعين من الكتانين أحدهما الأصلية وهي كاوتش والثانية المصنعة محلياً وهي الحديدية كل على حده. أظهرت النتائج المتحصل عليها نجاح استخدام الكومباين الياباني المجهز بالكتينة الحديدية في حصاد محصول القمح، وأظهرت ان العوامل المثلى للتشغيل كانت عند سرعة تقدم 0.72 م/ث عند مواصفات الكتينة المعدنية سالفة الذكر واثبتت تفوق الكتينة المعدنية كالاتي:

1. أعلى كفاءة جر كانت للكتينة المعدنية 83,1%
2. أعلى معامل شد كان للكتينة المعدنية 78,1%
3. أعلى قوة جر على اكس العجلة المسننة للكتينة المعدنية حوالي 15 كيلو نيوتن
4. أعلى معدل اداء للكومباين باستعمال الكتينة المعدنية 89. و. فدان/ساعة
5. أقل مقاومة تدحرج كانت للكتينة المعدنية 1,99 كيلو نيوتن
6. حدود قوة الشد كانت من 3,5 إلى 20,1 كيلو نيوتن عند حدود انزلاق من 2,4% إلى 6,1%
7. معدل استهلاك الوقود 8,1 لتر /ساعة
8. تأثير اتجاه حركة الكومباين في الدوران عند نهاية كل جرة ظهر في حسابات كل من معدلات الاداء واستهلاك الوقود والطاقة لكلا الكتينتين .
9. نسبة الزيادة في العائد من موسم حصاد القمح بالكومباين المجهز بالكتينة الحديدية 9% عنه في حالة استعمال الكتينة الكاوتش وتكلفة تصنيع الكتينة الواحدة (ثمن البيع) حوالي 1700 جنيه مصري.