



Answer the following questions:

Question 1

35 marks

- (A) (i) Express each force in Cartesian vector form.
 (ii) Determine *analytically* and *graphically* the magnitude of the resultant force and its direction. (10 marks)

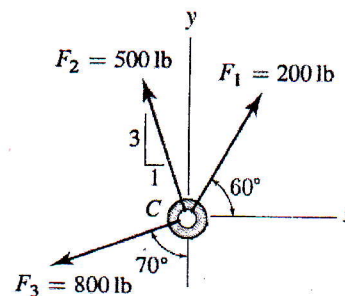

- (B) Two electrically charged pith balls, each having a mass of **0.15 g**, are suspended from light threads of equal length. Determine the magnitude of the horizontal repulsive force, F , acting on each ball if the measured distance between them is $r = 200 \text{ mm}$. (5 marks)

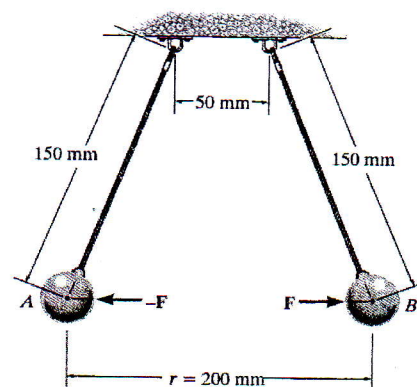

- (C) Three forces act on ring. If $\theta = 30^\circ$, and $\phi = 45^\circ$, determine:
 (i) Express each force in Cartesian vector form.
 (ii) The angle between the two forces F_1 and F_3 .
 (iii) The magnitudes of the components of force F_1 acting along and perpendicular to the line of action of F_3 .
 (iv) The magnitude and coordinate direction angles of the resultant force.
 (v) The magnitude and coordinate direction angles of the resultant moment about point A. (10 marks)

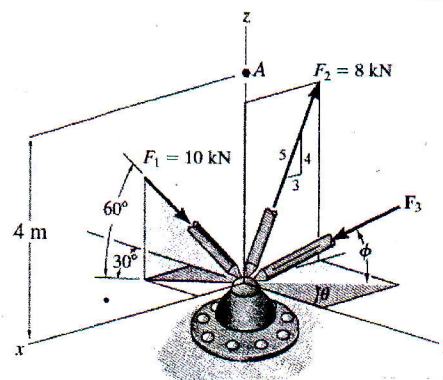

- (D) (i) For the given system of forces shown in the figure, If $x = 3 \text{ m}$, determine analytically the resultant force carried by the beam and its four properties.
 (ii) Determine *graphically* the distance x for which the resultant of the four forces would act at the center of the span AB. (10 marks)

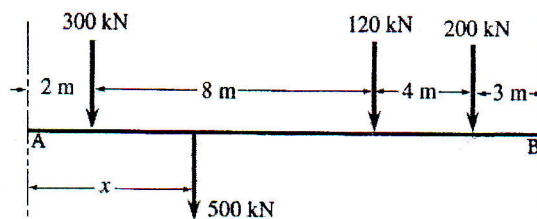

Question 2

35 marks

- (A) Spring CD remains in the horizontal position at all times due to the roller at D . If the spring is unstretched when $\theta = 0^\circ$ and the bracket achieves its equilibrium position when $\theta = 30^\circ$, determine the stiffness k of the spring and the horizontal and vertical components of reaction at pin A . (5 marks)

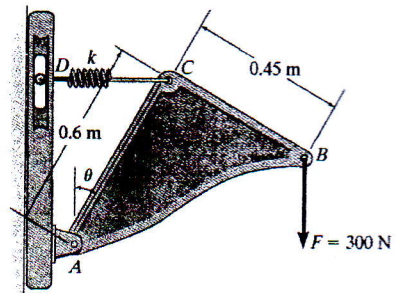

- (B) Determine analytically (*Joints method*) the force in each member of the truss. State if the members are in tension or compression. (10 marks)

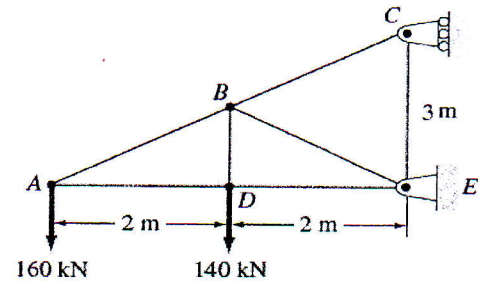

- (C) For the truss shown in the figure, put $W = 500 \text{ N}$. Determine;
 i) The force in members BD , CD , and CE . State if the members are in tension or compression. (*Using sections method*).
 ii) The force in each member of the truss. State if the members are in tension or compression. (*Using graphically method*).

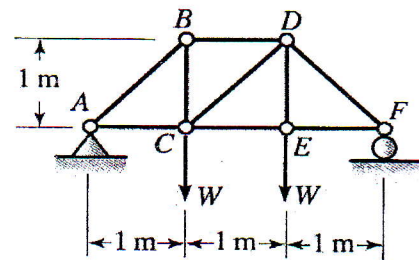

(10 marks)

- (D) (i) Determine the tension in the cables in order to support the 500-kg crate in the equilibrium position shown.
 (ii) Determine the maximum mass of the crate so that the tension developed in any cable does not exceed 15 kN.

(10 marks)

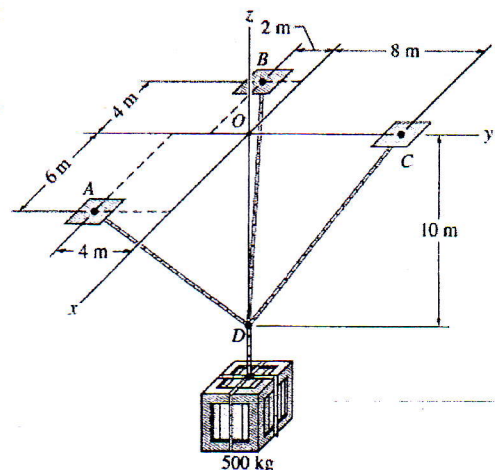

Second part (Dynamics)

Question 3 [40 marks]

(A) A particle travels along a straight line with a velocity $v = (12 - 3t^2) \text{ m/s}$, where t is in seconds. When $t = 1 \text{ s}$, the particle is located 10 m to the left of the origin (نقطة الأصل). Determine the acceleration when $t = 4 \text{ s}$, the displacement from $t = 0$ to $t = 10 \text{ s}$, and the distance which the particle travels during this time period. Also, find the average velocity and the average speed. [8 marks]

(B) The a - s graph for a jeep traveling along a straight road is given for the first 300 m of its motion. Construct the v - s graph. Note, at $s = 0$, $v = 0 \text{ m/s}$.

[8 marks]

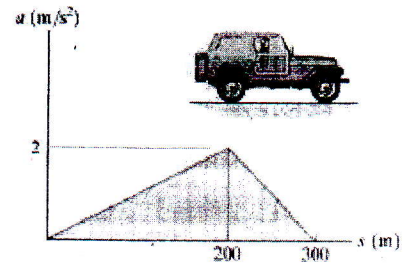

(C) The bob of a 2-m pendulum describes an arc of circle in a vertical plane. If the tension in the cord is 2.5 times the weight of the bob for the position shown, find the velocity and the acceleration of the bob in that position.

[8 marks]

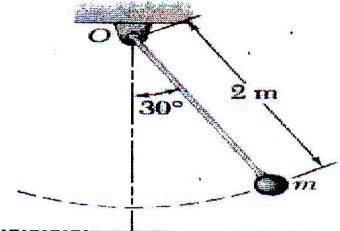

(D) For a particle moves in a straight line, the position - time graph is shown:

1- Does the particle start from rest? Why?

2- Does the particle change its direction during 7 time interval?

3- Calculate the following through 7 time interval:

(i) displacement (ii) average velocity

(iii) total distance traveled (iv) average speed

4- Describe the acceleration (show its type, acceleration or deceleration through (0-3),

(3-5) and (5-7) time interval. [8 marks]

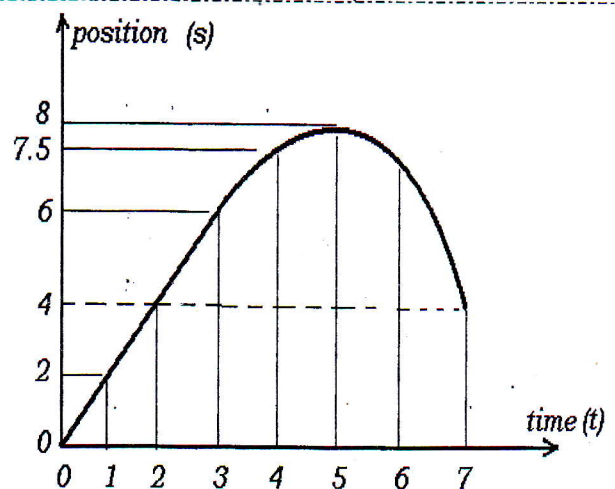

(E) The given graph represents the relation between the velocity and time through 40 seconds time interval for a particle moves in a straight line:

1- State the value of the acceleration in each interval and show the type of acceleration (acceleration or deceleration)

2- Does the particle change its direction through this interval? Why?

3- What the area under this curve represent?

[8 marks]

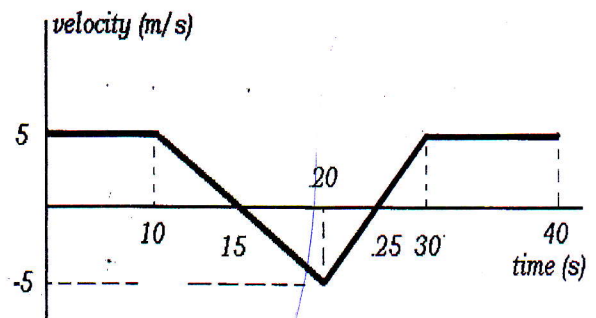

Question 4 [30 marks]

(A) The slotted arm AB drives pin C through the spiral groove described by the equation $r = 1.5\theta$ ft, where θ is in radians. If the arm starts from rest when $\theta = 60^\circ$ and is driven at an angular velocity of $d\theta/dt = \dot{\theta} = 4t$ rad/s, where t is in seconds, determine the radial and transverse components of velocity and acceleration of the pin C when $t = 1$ s.

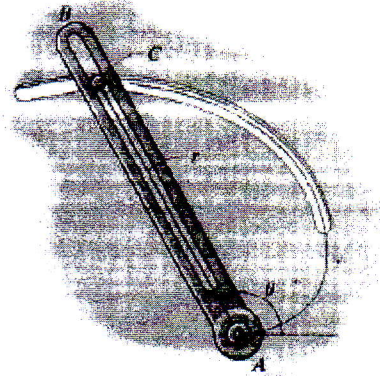

[8 marks]

(B) The 100 N (≈ 10 Kg) block A is traveling to the right at $v_A = 2$ m/s at the instant shown. If the coefficient of kinetic friction is $\mu_k = 0.2$ between the surface and A, determine the velocity of A when it has moved 4 m. Block B has a weight of 200 N (≈ 20 Kg).

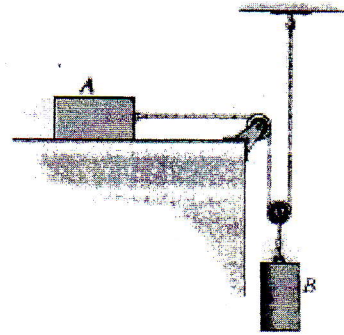

[8 marks]

(C) The crate, which has a mass of 100 kg, is subjected to the action of the two forces (1000 N and 800 N). If it is originally at rest, determine the distance it slides in order to attain a speed of 6 m/s. The coefficient of kinetic friction between the crate and the surface is $\mu_k = 0.2$.

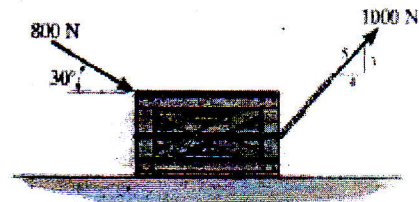

[8 marks]

(D) It is observed that the time for the ball to strike the ground at B is 2.5 seconds. Determine the speed v_A and angle θ_A at which the ball was thrown.

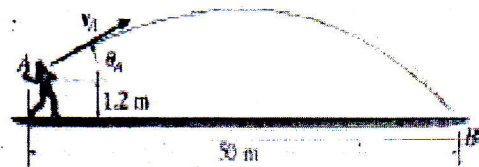

[6 marks]

This exam measures the following ILOs												
Question Number	Q1-a	Q2-c	Q2-b	Q3-b	Q4-a	Q1-c	Q2-a		Q1-b	Q3-e	Q3-b	
Skills	Q4-b	Q4-d			Q3-a	Q3-c			Q3-d	Q4-c	Q1-d	
	Knowledge & understanding skills				Intellectual Skills				Professional Skills			

With our best wishes

Associate Prof. Dr. Islam M. Eldesoky

Dr. Ramzy A. Abumandour