

## Effect of hydraulic shock loads on the performance of GRABBR & UASB reactor

### دراسة تأثير تغير الأحمال العضوية والهيدروليكية على المعالجة اللاهوائية باستخدام (UASB) و (GRABBR)

A. F. Ashry

Prof. of Sanitary Eng.,  
Public Works Dept.,  
Faculty of engineering  
Mansoura University, Egypt  
Udscenter@Gmail.com

R. M. El Shehawy

Lecturer of Sanitary Eng.,  
Public Works Dept.,  
Faculty of engineering  
Mansoura University, Egypt  
Dr\_ragab\_nmna@yahoo.com

M. Hakim

Teaching assistant  
Public Works Dept.,  
Faculty of engineering  
Mansoura University, Egypt  
totohakim@yahoo.com

#### الخلاصة

يعتبر المفاعلين اللاهوائيين (GRABBR) و (UASB) من أحدث تكنولوجيات المعالجة اللاهوائية ذات المعدل العالي وهما يتميزان عن باقي طرق المعالجة اللاهوائية ببعض الخواص. يتميز مفاعل (GRABBR) بوجود قاع من الرسوبيات النشطة مثل مفاعل (UASB) و أيضاً بقدرته على الفصل بين عملية تكوين الأحماض العضوية وعملية تكوين غاز الميثان مثل المفاعل اللاهوائي (ABR). هذه الدراسة توضح أداء كلا من المفاعلين نتيجة التعرض إلى مجموعة من الصدمات الهيدروليكية الناتجة عن زيادة في التصريف. تعرض كلا من المفاعلين إلى زيادة في الحمل العضوي من 3 إلى 60 kg COD m<sup>-3</sup> d<sup>-1</sup> عن طريق تقليل زمن بقاء المياه الهيدروليكي من 20 ساعة إلى 1 ساعة عند درجة حرارة 35 درجة مئوية. استخدمت مياه صرف صناعية تحتوي على الجلوكوز كمصدر أساسي للمواد العضوية. حقق مفاعل (GRABBR) نسبة إزالة للمواد العضوية تتراوح من 89,40% إلى 57,76% مع إنتاج كمية من غاز الميثان وأيضاً حقق مفاعل (UASB) نسبة إزالة للمواد العضوية تتراوح من 82,12% إلى 51,20% مع إنتاج كمية من غاز الميثان وبذلك أستطاع كلا من المفاعلين تحقيق كفاءة مع حدوث التغير السريع للتصريف. لوحظ بوضوح عملية الفصل بين كلا من عملية تكوين الأحماض العضوية وعملية تكوين غاز الميثان في مفاعل (GRABBR) عند تعرضه لأحمال عضوية عالية حيث كانت البكتريا المنتجة للأحماض تسكن بداية المفاعل و الأخرى تسكن بالقرب من مخرج المياه. لوحظ أيضاً زيادة زمن بقاء البكتريا في المفاعلين بغض النظر عن زمن بقاء المياه وذلك يرجع إلى قدرة الرسوبيات النشطة على الترسب. عملت الرسوبيات النشطة في مفاعل (GRABBR) كمرشح للمياه مما أدى إلى تقليل نسبة المواد العالقة في المياه المعالجة و زيادة زمن بقاء البكتريا في المفاعل. هذه الدراسة أشارت إلى أن كلا من المفاعلين يستطيع معالجة مياه الصرف تحت التغير في التصريف.

#### Abstract

The granular bed baffled reactor (GRABBR) and the upflow anaerobic sludge blanket (UASB) are considered as the novel types of the high rate anaerobic reactors with distinct advantages over other types of anaerobic reactors. The GRABBR is an anaerobic reactor characterized by its granular sludge bed like the UASB and compartmentalized like the ABR. This thesis describes the performance of both of the reactors when receiving unpredictable hydraulic shock loads. Shock loads were created by rapidly increasing volumetric organic loading rates from 3 to 60 kg COD m<sup>-3</sup> d<sup>-1</sup>, along with decreasing the hydraulic retention time from 20 hrs to 1 hr. Synthetic wastewater containing glucose as the main organic compound was used in this study. The GRABBR and the UASB reactor achieved chemical oxygen demand (COD) removal of 58% - 89% and 51% - 82% respectively with high methane production. Both of the reactors appeared to possess high tolerance to rapid hydraulic changes with fast recovery time. Marked phase separation between different micro-organisms occurred in the GRABBR at high organic loading rates, with acidogenesis and methanogenesis being the respective dominant

activities in the upstream and downstream compartments of the reactor. Granular biomass possessed good settling characteristics, which encourage high biomass retention within the system.

## Key Words

GRABBAR, UASB, HRT, Performance, OLR, Biogas, Volatile fatty acids.

## Introduction

Anaerobic technology for wastewater treatment has become a popular choice over recent years, especially for the treatment of high strength wastewaters. The increased utilization of anaerobic systems has been associated with the development of high-rate reactors that are able to separate hydraulic retention time (HRT) from solid retention time (SRT), which enable the retention of slow growing micro-organisms within the reactor system, independent on the wastewater flow.

The performance of anaerobic processes is generally regarded suitable for steady effluent with less variation in composition and flow. However, shock loads could adversely affect the performance of anaerobic reactors by producing unfavorable conditions for microbial populations. This can lead to an environmental favorable to the growth of one microbial population (acidogens), which may produce conditions within the media that may constitute a limiting factor to the other group of organisms (methanogens). Such conditions encourage volatile fatty acids (VFAs) accumulation and upset the microbial ecology within the anaerobic system (Shin et al., 2001).

Phase separation between acidogenesis and methanogenesis has been found to improve process stability in the treatment of wastewater at various operational conditions (Shin et al., 2001). Anaerobic baffled reactor (ABR) is one of the high rate anaerobic systems that are capable of creating

phase separation between different microbial populations by accommodating them in different compartments or zones with high solids retention (Barber and Stuckey, 1999).

The most popular high-rate anaerobic reactor configuration in the world today is the UASB (Cheng et al., 1990; Fang et al., 1994; Barber and Stuckey, 1999). The success of the UASB depends on the formation of active and settle-able granules (Fang et al., 1994). This enhances the settleability of the biomass and leads to an effective retention of bacteria in the reactor (Yan and Tay, 1997).

Akunna and Clark (2000) brought the properties of the ABR systems and the anaerobic granules sludge together to create the anaerobic granular bed baffled reactor (GRABBR) system. The GRABBR is one of the newest developed anaerobic reactors, which combines the advantage the ABR and the UASB reactor by incorporating granular biomass from the UASB reactor in the ABR.

This study aimed to evaluate the stability of the GRABBR and the UASB reactor during shock load conditions created by an increase in hydraulic loadings. The study was carried out with synthetic glucose wastewater under mesophilic conditions.

## Materials and methods

### Reactors Set-up

The laboratory scale GRABBR and UASB systems were made of Perspex and are shown in figure 1 and figure 2. The detailed design descriptions of the

reactors are shown in table 1 and table 2. The UASB was designed to have an up flow velocity of 0.65 m/hr at a hydraulic retention time of 1 hr. Sampling ports were provided for liquid and gas collection. A constant temperature of 35 °C was maintained by recirculating heated water through a water jacket attached to both of the reactors. The raw wastewater (influent) was pumped into the reactor by using a variable speed Masterflux peristaltic pump. Treating effluent level and excess solids washout was controlled using a U-tube at the effluent discharge point.

Table 1. Dimension of the laboratory scale GRABBR

Parameter	Value
External dimension (cm <sup>3</sup> )	50 x 12 x 32
Working volume (liters)	10 Liters
Number of compartments	5
Working volume of each compartments (liters)	2
Number of sampling port in each compartment	2
Thickness of protective baffle (mm)	4
Thickness of hanging baffle (mm)	4

Table 2. Dimension of the laboratory scale UASB

Parameter	Value
External diameter (mm)	180
Internal diameter (mm)	140
Diameter of the inlet (mm)	20
Distance between the baffles (mm)	20
Horizontal angle of the conical base (°)	60
Vertical angle of conical base (°)	30
Working volume (liters)	10
Height based on 10 liters volume (cm)	65
Final volume (liters)	11.50

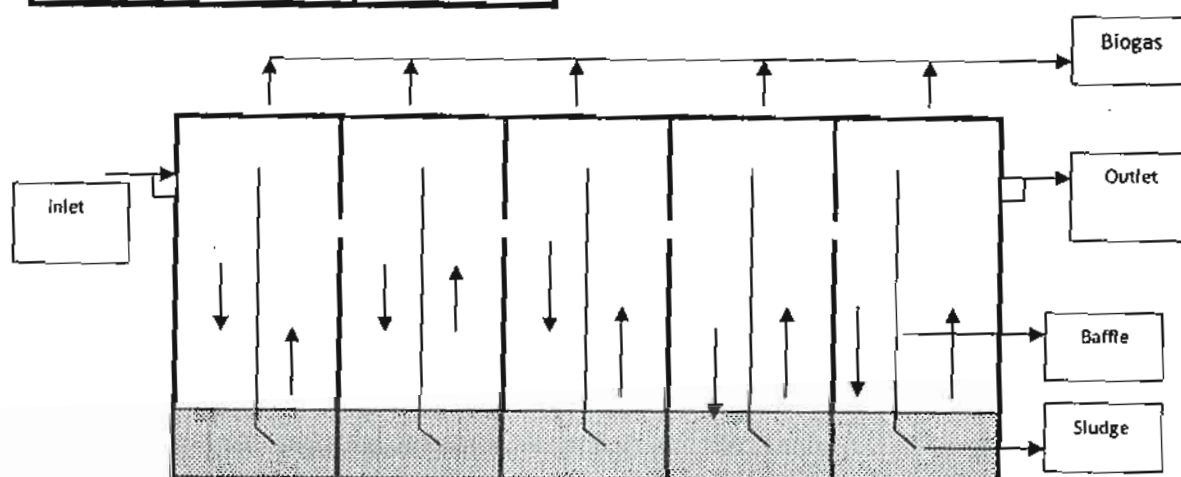

Figure 1. Cross-sectional frontal view of the laboratory scale GRABBR.

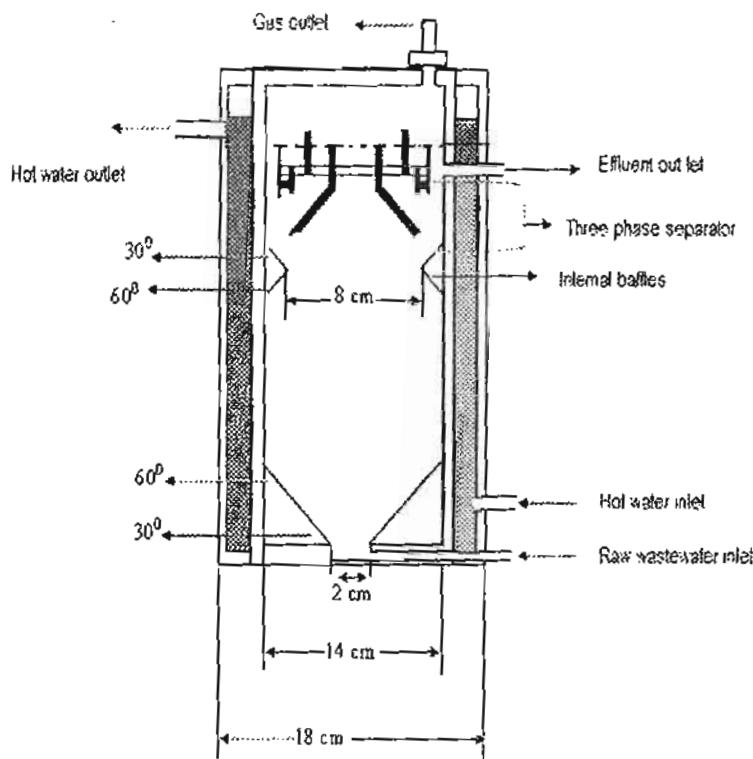

Figure 2. Cross-sectional frontal view of the laboratory scale UASB.

### Raw Wastewater

The synthetic medium contained glucose as the main carbon source. During the experimental period, the synthetic feed was prepared by mixing all the components of right composition and then it was diluted with measured tap water in 60L container to make it up to the right concentration (2500mg/L COD). Sodium carbonate and sodium hydroxide was the main buffering agent whilst other macro and micronutrients were contributed by various other chemicals to balance the solution. The composition of the solution is given in the Table 3.

Throughout the experiment the pH of the controlled feed was about 8.3.

### Seed sludge

Granular sludge was obtained from a 1600 m<sup>3</sup> UASB reactor in Aberdeen, UK, used to treat paper mill wastewater. The UASB reactor has been in operation for more than 10 years. It is operating under mesophilic conditions (35°C). The sampling point for granules was 2 m above the bed of the UASB reactor. The UASB reactor was operating at an organic loading rate (OLR) of 12 Kg COD m<sup>-3</sup> d<sup>-1</sup> and hydraulic retention time (HRT) of 8 hrs, with a COD removal efficiency of 66 %.

Table 3 Synthetic Feed Composition

Material	Concentration (mg/l)
Glucose (C <sub>6</sub> H <sub>12</sub> O <sub>6</sub> )	5000
Sodium hydrogen carbonate (NaHCO <sub>3</sub> )	2500
Ammonium hydrogen carbonate (NH <sub>4</sub> HCO <sub>3</sub> )	1000
Sodium hydroxide (NaOH)	1500
Potassium di-hydrogen phosphate (KH <sub>2</sub> PO <sub>4</sub> )	400
Calcium chloride (CaCl <sub>2</sub> )	5
Magnesium sulphate (MgSO <sub>4</sub> )	5
Ferric chloride (FeCl <sub>3</sub> )	5
Potassium chloride (KCl)	5
Cobalt chloride (CoCl <sub>2</sub> )	1
Nickel chloride (NiCl <sub>2</sub> )	1

### Experimental design

After seeding the reactors, the start up was initiated by feeding a tap water for two days in order to get rid of dispersed sludge as well as to ensure that the cylinder was in an appropriate situation (no leakage, inlet and out let streams flowing normally for both inner and outer cylinders) to start feeding by synthetic wastewater. Shock loads were created by increasing the hydraulic loading rates in very short intervals of time, while maintaining the concentration of the feed constant. The reactor was started with an OLR of 3 Kg COD m<sup>-3</sup> d<sup>-1</sup> which corresponded to an HRT of 20 hrs and it gradually increased until it reaches an OLR of 60 Kg COD m<sup>-3</sup> d<sup>-1</sup> which corresponded to an HRT of 1 hr. The system was operated continuously for 101 days. Loading rates were increased when a relatively small variation in the SCOD and pH of the final effluent for two different samples was observed, hence termed as steady state condition in the study. The results in this study were

based on the samples analysis obtained just before changing the loading rate.

### Analysis

SCOD was determined using colorimetric method on Direct Reading DR/2000 Spectrophotometer (Hach, Loveland USA). pH values were obtained using pH meter M240 (Corning, Sudbury UK) fitted with Ross pH Combination electrode 8102 (Orion, Beverly USA). Gas volume was measured using water displacement method. The extent of methane and carbon dioxide composition in the biogas was measured according to the standard methods for analysis of sludge digester gas (H.M.S.O, 1979). The digester gas was bubbled several times through one liter of 40% molar caustic solution of Potassium hydroxide (KOH) (until no change in volume was could be detected) which absorbed all the Carbon dioxide according to the following reaction. The final volume of gas was measured again by water displacement method and it refers to the amount of methane.

VFAs Volatile fatty acids (acetate, propionate, butyrate and valerate) were determined using a Unicam 610 series Gas chromatograph (GC) with auto sampler and PU 4811 computing integrator. The GC column was 2m X 2mm inside diameter glass packed with 10% AT - 1000 on 80/100 Chromosorb W - AW, with a column temperature of 1400 C on flame Ionization Detector (FID). The carrier gas was nitrogen at a flow rate of 20ml/min at 1800 C. In order to analyze biosolids wash out during the experiment, determination of the total suspended solids were carried out as recommended by standard methods (APHA, 1992).

## RESULTS

### Soluble COD removal

SCOD removal efficiency decreased for both of the reactors as the HRT decrease. The UASB has its maximum COD removal efficiency (82.12%) at HRT 20 hrs and its minimum COD removal efficiency (51.3%) at HRT 1 hr. Also The GRABBR has its maximum COD removal efficiency (89.24%) at HRT 20 hrs and its minimum COD removal efficiency (57.76%) at HRT 1 hr.

The effect of the hydraulic shock load was clearly observed during the operation of the reactors, immediately after changing the OLR some disturbances in the reactor performance were observed (for example, appearance of large gas bubbles in the sludge bed zone and partial sludge flotation). However, after a period of time (3-6 hydraulic retention times, HRTs), this undesirable phenomenon was generally eliminated.

Figure 3 and figure 4 show that the efficiency of the COD removal

decreased gradually with the increases of OLR and the decrease in the HRT. It can be explained that the COD removal efficiency was high at longer HRT, because the influent flow rate was low enough to provide better contact between the wastewater and the biomass (microorganisms) which lead to an optimum degradation of organic matter.

At lower loading rates or long HRT, the GRABBR operated as one completely mixed unit without any noticeable phase separation. Phase separation occurred at high loading rates (or short HRT), resulted in mainly acidogenesis occurring in the early compartments and methanogens is in the latter compartments. The same result was observed by Baloch and Akunna, 2003b.

### pH results

Figure 5 shows the pH of the UASB reactor for each HRT. For the over all experiment period, the pH values ranged from 6.10 as the lowest pH during the OLR of 1 kgCOD/m<sup>3</sup>.d to the highest pH value of 6.8 during the OLR of 12 kgCOD/m<sup>3</sup>.d for the UASB.

Figure 6 shows the pH profile for each HRT of the GRABBR. pH in the first and second compartments of the GRABBR was similar for most of the OLR owing to the acidogenesis. At lower loading (3-7.5 kg COD/m<sup>3</sup>.day), pH changes were moderate in all the compartments of the GRABBR. When the OLR was increased to 10 kg COD/ m<sup>3</sup>.d, there was a marked fall in the pH of all the compartments. This was expected because of the production of more acids at high OLR in the early compartments. In general, pH values increased down stream the reactor due to the degradation of VFA in the latter compartments. The pH

profile of the GRABBR gives an indication of the degree of different phases created within the reactor.

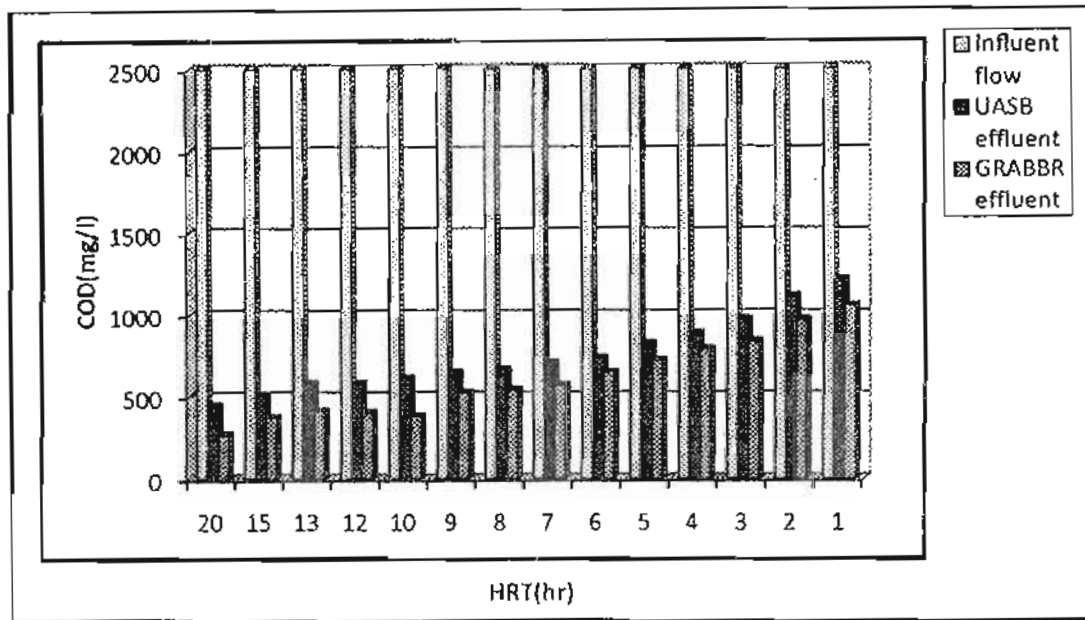

Figure 3 COD influent and effluent at different HRT

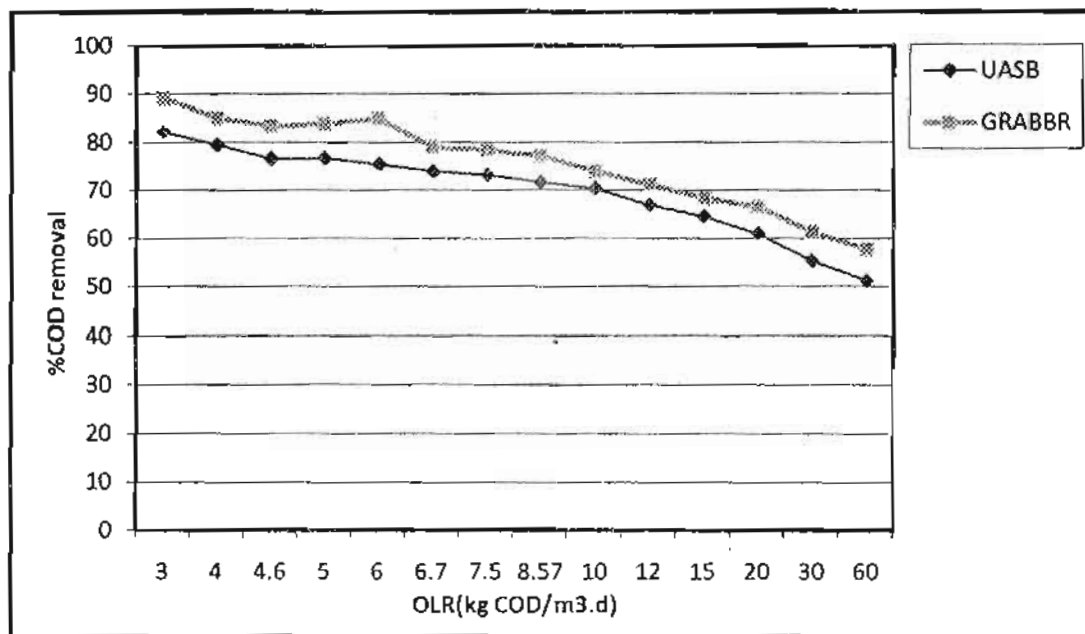

Figure 4 COD removal efficiency during different OLR

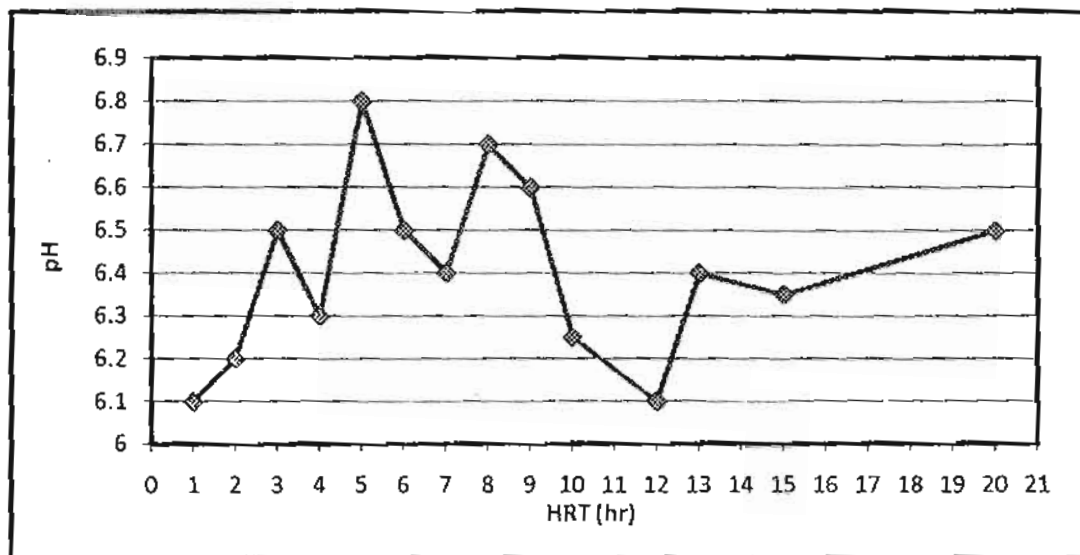

Figure 5 pH of the UASB reactor at different HRT

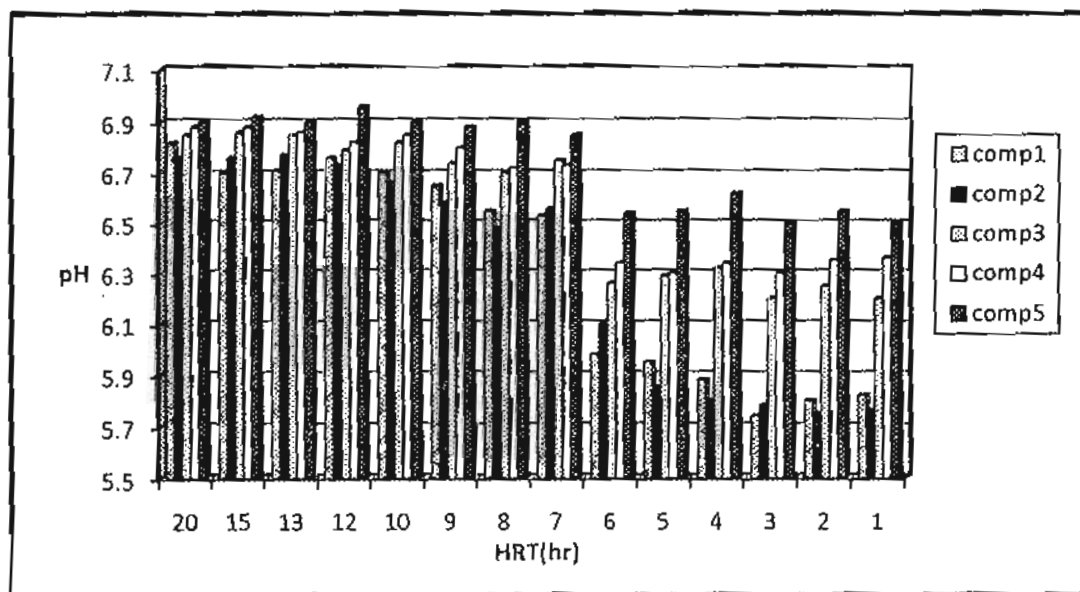

Figure 6 pH of the GRABBR at different HRT

### TSS and biomass washout

Total suspended solids (TSS) concentrations of the effluent flow were measured in the range of 94 to 421 mg/l for the UASB and 61 to 372 mg/l for the GRABBR. Most of the solids washout consisted of non granular newly-formed microbial mass and debris of broken granules.

It was observed that the granules in the lowest part of the sludge bed zone of the UASB were mainly large and black or gray, whereas those taken from the higher part were smaller and lighter in color; similar observation has been made by kalyuzhnyi et al, 1996.

When the UASB was initially started, the original dark seed granular sludge was the only biomass in the reactor.



Soon after start up, gray and white sticky mass started to form and spreading with the decreasing of HRT. This indicate the increase of acidogens compared to methanogens as acidogens are mostly hydrophilic (or non-granule-forming) while methanogens are hydrophobic (or granule-forming) (Daffonchio et al., 1995).

Different characteristics of the granular sludge bed of the GRABBR were observed in the acidogenic and methanogenic dominant zones. Granule flotation and breaking (non granular biomass) were observed in the front compartments and it start to spread as the HRT decrease, where acidogenesis was the dominant activity, while most of the granular sludge was observed in the latter compartments of the GRABBR, where methanogenesis was the dominant activity. Similar observations has been made (Akunna and Clark., 2000; Baloch and Akunna., 2003a).

Figure 7 shows a comparative graph that illustrates the reactors performance in term of biomass wash out at varying HRT. The graph shows clearly the increase of biomass washout with the decrease of HRT and increase of flow rate. It is clear that as the HRT decrease the flow velocity inside the reactor increase and more biomass washout is likely to occur. GRABBR shows better performance than the UASB in terms of biomass washout especially in 6 hr HRT and less. This

may because of the baffles that minimized inter-compartmental biomass washout and also that the granular bed of the downstream acts as a filtration bed for non granular biomass formed in the acidogenic phase as reported in Baloch and Akunna., 2003b. With lower HRT the total biomass washout increased due to the combined effect of gas production and high velocity of the fluid flow inside the reactors.

### Volatile fatty acids

The accumulation of volatile fatty acids (VFA) can be a typical reactor response during the variation in hydraulic and organic loading rates. Figure 8 shows the VFA results for both of the reactors (UASB and GRABBR) during various HRT and flow rate. The results of the VFA are going with the results of the COD removal efficiency. As the HRT decrease the VFA increase and the COD removal efficiency decreased. A noticeable decrease in the effluent quality was observed when the loadings were initially increased from 10 to 60 kg COD m<sup>-3</sup> .d<sup>-1</sup>. This increase of VFA during high organic loading indicates that the production of acids by the acidogenic bacteria is more than that the methanogenic bacteria can utilize, so methanogenic bacteria need more time to be adapted for this conditions to give better effluent quality.

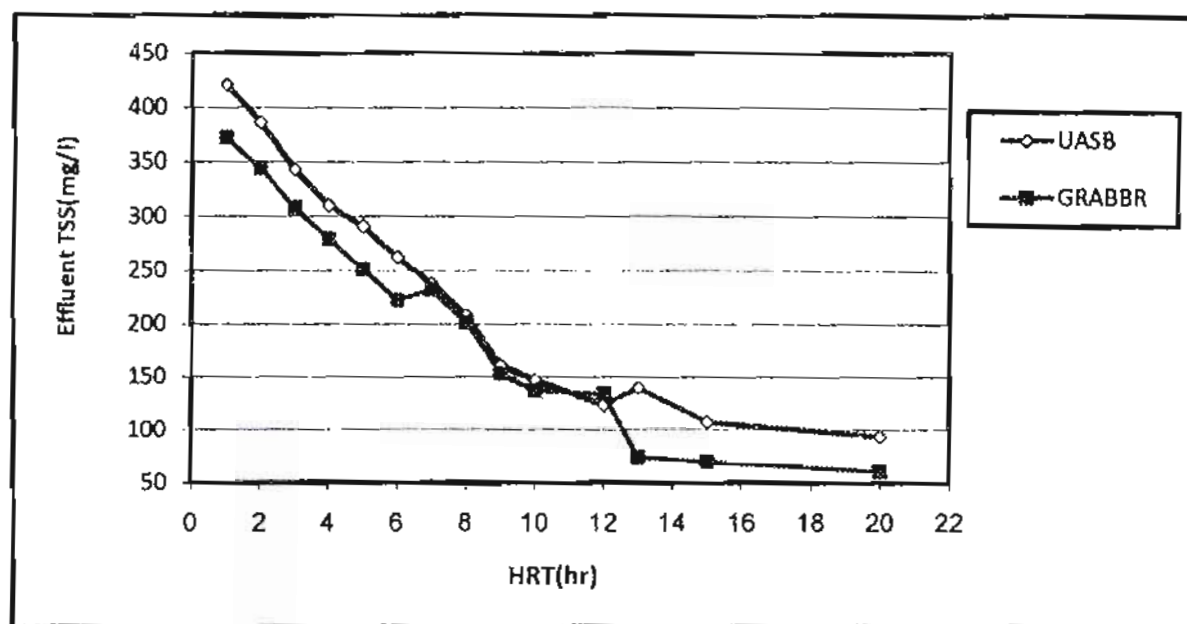

Figure 7 Effluent TSS results of the UASB and the GRABBR with different HRT

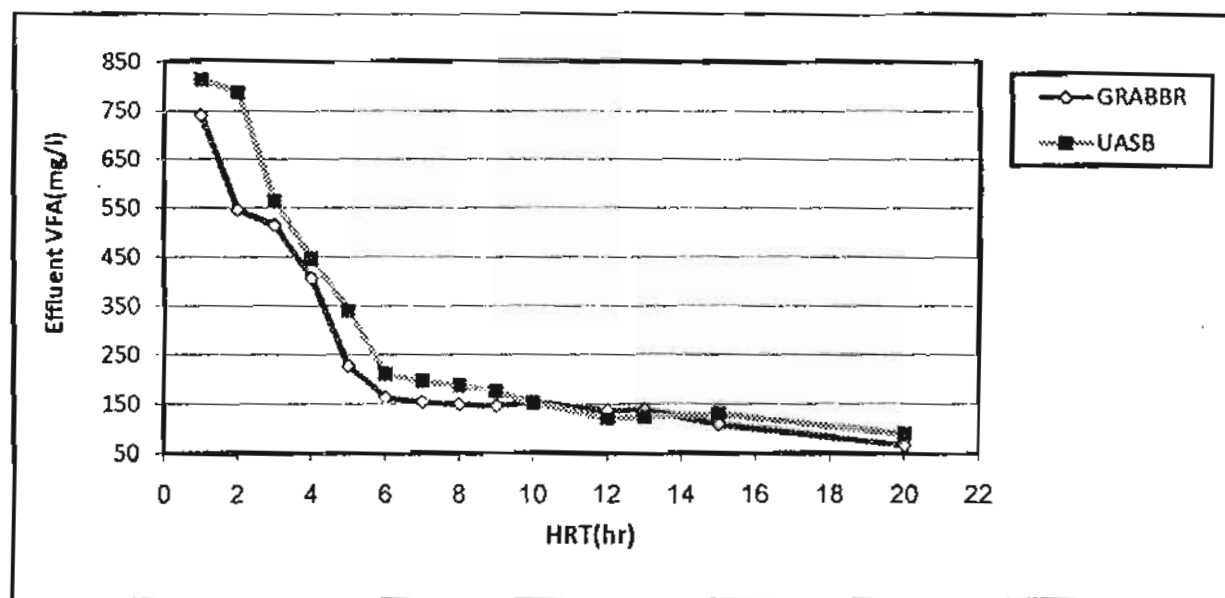

Figure 8 Effluent VFA of the UASB and the GRABBR at different HRT

### Biogas Production

Gas production increased with increases in organic load, increasing from 8.76 to 60.6 l/d of biogas for the UASB and from 8.45 to 60.2 for the GRABBR for an OLR of 3-60 kg COD m<sup>-3</sup> d<sup>-1</sup>. Methane composition varied

from 66.4 % to 69.5 % for the GRABBR and from 66 % to 68.3 % for the UASB during the entire reactor operation and the remainder consists of a mixture of carbon dioxide, nitrogen, water vapor and a small amount of hydrogen sulphide.

Although gas production occurred within all the GRABBR compartments, the chief contributors were the 4th and 5th compartments because of the methanogenic bacteria located in these compartments. The composition of the biogas in the earlier compartments was mainly carbon dioxide while the latter compartments produce up to 75% of the total methane produced.

It was observed that the production of biogas was so little in the first hours of operation on a specific OLR and after this it increases gradually, so that the reactors may give better results if it was operated for a longer time on the same OLR before changing it.

### CONCLUSIONS

The UASB reactor in this study was able to attain SCOD removal efficiencies of 82.12% to 51.3% for OLRs of 3 to 60 kg COD m<sup>-3</sup>d<sup>-1</sup> (HRTs of 20 hrs to 1 hrs) at steady state conditions. The GRABBR was able to achieve SCOD removal efficiencies of 89.24% to 57.76% for OLRs of 3 to 60 kg COD m<sup>-3</sup> d<sup>-1</sup> (HRTs of 20 hrs to 1 hrs) at steady state conditions. This study demonstrated that both of the GRABBR and the UASB systems have a high tolerance to sudden increase in the flow rate (OLR) with little decrease in the effluent quality, but the GRABBR gives a higher effluent quality than the UASB system. The capability of the UASB to achieve high treatment efficiency during hydraulic shock loads were attributed mainly to the active and dense nature of the granular bed in the reactor, while the capability of the GRABBR depends mainly on its phase separation characteristics and also on the highly active and dense nature of the granular bed of the reactor.

For the GRABBR, it was observed that the number of compartments of the

reactor involved in the treatment increased with increasing the OLR. As the flow rate increased, phase separation becomes more apparent because each compartment behaves as a specialized treatment unit, in which the acidogenic bacteria dominating the upstream compartments, while the methanogenic bacteria dominating the downstream compartments of the reactor. The formation of non granular biomass was observed along with granular breaking and flotation in the compartments where acidogenic bacteria was dominant, while the granular biomass accumulated in the methanogenic zone. Increasing the OLR cause an increase of acidogenic bacteria over methanogenesis. This study showed that the GRABBR could minimize the biomass washout even at relatively short HRTs, because of the dense nature of the granular bed in the reactor. However, the obtained results showed an inverse relationship between the HRT and the biomass washout.

The GRABBR and the UASB reactor configurations offer quick recovery from shock loads, high retention of active biomass, optimum contact between wastewater and biomass, and high methane yield under various operational conditions. The GRABBR shows better performance in term of biomass washout and COD removal efficiency as it offers separation between different microbial groups along the reactor flow gradient. Both of the reactors appear to be stable for the treatment of wastewater with wide fluctuation in flow rate.

It is not easy to compare the results of the present study with other studies because each study points to a limited range of operational conditions and also most of these studies involved different start-up strategy or HRT

which is one of the most important phases that affect the performance of anaerobic treatment of wastewater.

## REFERENCES

1. Akunna, J. C. and Clark, M. (2000) Performance of a granular-bed anaerobic baffled reactor (GRABBR) treating whisky distillery wastewater. *Bioresour. Technol.*, 74, 257-261.
2. American Public Health Association (APHA). (1992). Standard methods for the examination of water and wastewater. 18th Ed., Washington, D.C., USA.
3. Baloch, M. I. and Akunna, J. C. (2003a). Effect of rapid hydraulic shock loads on the performance of granular bed baffled reactor. *Environ., Technol.*, 24, 361-368.
4. Baloch, M. I. and Akunna, J. C. (2003b). Granular bed baffled reactor (Grabbr): Solution to a two-phase anaerobic digestion system. *J. Environ. Engrg. (ASCE)*, 129, 1015-1021.
5. Barber, W. P. and Stuckey, D. C. (1999). The use of the anaerobic baffled reactor (ABR) for wastewater treatment: A review. *Wat. Res.*, 33, 1559-1578.
6. Cheng, S.S., Lay, J.J., Wei, Y.T., Wu, M.H., Roam, G., Chang, T.C., (1990). A modified UASB process treating winery wastewater. *Water Sci. Technol.* 22 (9), 167-174.
7. Daffonchio, D., Thaveesri, J., Verstraete, W., (1995). Contact angle measurement and cell hydrophobicity of granular sludge from upflow anaerobic sludge bed reactor. *Appl. Environ. Microbiol.*, 61, 3676-3680.
8. Fang, H.H.P., Chui, H.K., Li, Y.Y., (1994). Microbial structure and activity of UASB granules treating different wastewaters. *Water Sci. Technol.* 30 (12), 87-96.
9. Hach. (1992). *Water Analysis Handbook*. 2nd ED., Hach Company, Loveland, Colorado, USA.
10. Kalyuzhnyi, S. V., Sklyar, V. I., Davlyatshina, M. A., Parshina, S. N., Simankova, M. V., Kostrikina, N. A. and Nozhevnikova, A. N. (1996). Organic removal and microbiological features of UASB-reactor under various organic loading rates. *Bioresour. Technol.*, 55, 47-54.
11. Shin, H. S., Han, S. K., Song, Y. C. and Lee, C. Y. (2001). Performance of UASB reactor treating leachate from acidogenic fermenter in the two-phase anaerobic digestion of food waste. *Wat. Res.*, 35, 3441-3447.
12. Yan, Y.G., Tay, J.H., (1997). Characterisation of the granulation process during UASB start-up, *Wat. Res.*, 31, 1573-1580.